



**SHIELD**

# Steel Pipes & Fittings



SHIELD

FMA

SHIELD

# Introduction

SHIELD is a company created to cater to the infrastructure, fire protection and building services industries with a comprehensive range of products designed to be competitive and of assured quality.

We stay ahead of today's evolving market requirements by committing to a program of continued research and development.

We are able to maintain our high standards by ensuring that our worldwide manufacturing networks are the most advanced in the industry in Europe, Asia and America in terms of quality and delivery lead time. Our fully experienced and professional staff is there to provide engineering expertise and after sales service exactly when you need it.

Combine this with highly responsive and customer focused network of distribution centres around the world, you will find that customer satisfaction is what we excel at.

We are justifiably proud of our global client base. With offices and facilities in the UK and Middle East, we are able to comprehend the specific needs of your particular region.

SHIELD  
PIPING  
SYSTEM

*Trusted Worldwide*

# Contents

	<b>Page</b>
<b>Pipes</b>	
Pipes (BS1387)	3
Pipes (ASTM A53)	4
<b>Threaded Fittings</b>	5
Elbow 90° - SDT-100	7
Reducing Elbow 90° - SDT-101	7
Elbow 45° - SDT-200	7
Tee - SDT-12	8
Reducing Tee - SDT-53	8
Reducing Coupling - SDT-30	9
Cross - SDT-13	9
Reducing Cross - SDT-51	9
Straight Coupling - SDT-22	10
Plug - SDT-55	10
Cap - SDT-14	10
Hex Bushing - SDT-57	11
Union - SDT-59	11
Hex Nipple - SDT-11	11
Hex Reducing Nipple - SDT-111	11
<b>Grooved Fittings</b>	12
Rigid Coupling - Standard - SDG-22	14
Rigid Coupling - Light - SDG-20	15
Flexible Couplings - Heavy Duty - SDG-27	15
Flexible Couplings - Standard - SDG-25	16
Flexible Couplings - Light - SDG-21	17
Reducing Couplings - SDG-30	18
Angle Pad - SDG-24	19
Elbows - 90° SDG-100, 45° SDG-200, 90° SDG-105	20
Elbows - 22.5° SDG-225, 11.25° SDG-112	21
Tee - SDG-12, Cross Tee - SDG-13, Tee - SDG-102	22
Cap - SDG-14	22
Grooved Flange - SDG-15, Adaptor Flange - SDG-16	23
Reducing Tee - SDG-53	24
Concentric Reducer Grooved - SDG-35, Threaded - SDG-37	25
Eccentric Reducer Grooved - SDG-33	26
Mechanical Tee Threaded Outlet - SDG-42	27
Mechanical Tee Grooved Outlet - SDG-44	28
Mechanical Cross Threaded - SDG-47	29
Mechanical Cross Grooved - SDG-49	30
Mechanical Tee U-Bolt - SDG-40	31
Groove Specifications	31
<b>Pipe Support &amp; Accessories</b>	32
Swivel Hanger - SD-HB	33
Clevis Hanger - SD-HC	34
Pipe Clamp with Lining - SD-GE-RLC	35
Pipe Clamp - SD-GE-PPC	37
U Strap Hanger with Lining - SD-GE-RUS	38
U Strap Hanger - SD-GE-US	39
Riser Hanger or Clamp with Lining - SD-GE-RRC	40
Riser Hanger or Clamp - SD-GE-PRC	41
U-Bolt - SD-UB	42
Rubber Support Insert - SD-RSI	43
Threaded Rod - SD-TR	44
Beam Clamp - SD-CBC	45



# Steel Pipes

For HVAC & Fire Fighting Applications





# Shield Pipes Technical Data

Black & Hot Dipped Galvanized Steel Welded Pipes  
Conforming to BS 1387:1985 (EN 10255)

C l a s s	Nominal Bore		Outside Diameter				Wall Thickness		Weight of Black Pipes						Weight of Galvanized Pipes (Calculated)						No. of pipes packed per standard bundle (1 Tonne Approx.)
			Maximum		Minimum				Plain Ended			Screwed & Socketed			Plain Ended			Screwed & Socketed			
	Inch	mm	Inch	mm	Inch	mm	Inch	mm	Kg/m	m/ton	ft/ton	kg/m	m/ton	ft/ton	Kg/m	m/ton	ft/ton	kg/m	m/ton	ft/ton	
L I G H T (A)	½	15	0.843	21.4	0.827	21.0	0.079	2.00	0.947	1056	3465	0.956	1046	3432	1.000	1000	3281	1.009	991	3251	160
	¾	20	1.059	26.9	1.039	26.4	0.091	2.30	1.380	725	2379	1.390	719	2359	1.440	694	2277	1.460	690	2264	110
	1	25	1.331	33.8	1.307	33.2	0.102	2.60	1.980	505	1657	2.000	500	1640	2.060	485	1591	2.090	478	1568	80
	1¼	32	1.673	42.5	1.650	41.9	0.102	2.60	2.540	394	1293	2.570	389	1276	2.640	379	1243	2.680	373	1224	61
	1½	40	1.906	48.4	1.882	47.8	0.114	2.90	3.230	310	1017	3.270	306	1004	3.350	298	978	3.400	294	965	51
	2	50	2.370	60.2	2.346	59.6	0.114	2.90	4.080	245	804	4.150	241	791	4.220	237	778	4.300	233	764	37
	2½	65	2.991	76.6	2.961	75.2	0.124	3.20	5.710	175	574	5.830	172	564	5.890	170	558	6.020	166	545	27
	3	80	3.492	88.7	3.461	87.9	0.124	3.20	6.720	149	489	6.890	145	476	6.930	144	472	7.100	141	463	24
	4	100	4.484	113.9	4.449	113.0	0.142	3.60	9.750	103	338	10.000	100	328	10.030	100	328	10.280	97	318	16
M E D I U M (B)	½	15	0.854	21.7	0.831	21.1	0.102	2.60	1.210	826	2710	1.220	820	2690	1.250	794	2605	1.260	787	2582	130
	¾	20	1.071	27.2	1.047	26.6	0.102	2.60	1.560	641	2103	1.570	637	2090	1.620	617	2024	1.640	610	2001	100
	1	25	1.346	34.2	1.315	33.4	0.124	3.20	2.410	415	1362	2.430	412	1352	2.490	402	1319	2.510	398	1306	65
	1¼	32	1.689	42.9	1.657	42.1	0.124	3.20	3.100	323	1060	3.130	319	1047	3.200	312	1024	3.230	310	1017	51
	1½	40	1.921	48.8	1.890	48.0	0.124	3.20	3.570	280	919	3.610	277	909	3.680	272	892	3.720	269	883	44
	2	50	2.394	60.8	2.354	59.8	0.142	3.60	5.030	199	653	5.100	196	643	5.170	193	633	5.250	190	623	30
	2½	65	3.016	76.6	2.969	75.4	0.142	3.60	6.430	156	512	6.550	153	502	6.610	151	495	6.730	149	489	24
	3	80	3.524	89.5	3.469	88.1	0.157	4.00	8.370	119	390	8.540	117	384	8.580	117	384	8.760	114	374	19
	4	100	4.524	114.9	4.461	113.3	0.177	4.50	12.200	82	269	12.500	80	262	12.480	80	260	12.690	79	259	14
H E A V Y (C)	½	15	0.854	21.7	0.831	21.1	0.124	3.20	1.440	694	2277	1.450	690	2264	1.490	671	2202	1.500	667	2188	110
	¾	20	1.071	27.2	1.047	26.6	0.124	3.20	1.870	535	1755	1.880	532	1745	1.930	518	1700	1.950	513	1683	80
	1	25	1.346	34.2	1.315	33.4	0.157	4.00	2.940	340	1115	2.960	338	1109	3.010	332	1089	3.040	329	1079	55
	1¼	32	1.689	42.9	1.657	42.1	0.157	4.00	3.800	263	863	3.830	261	856	3.900	256	840	3.930	254	833	44
	1½	40	1.921	48.8	1.890	48.0	0.157	4.00	4.380	228	748	4.420	226	741	4.490	223	732	4.530	221	725	37
	2	50	2.394	60.8	2.354	59.8	0.177	4.50	6.190	162	531	6.260	160	525	6.330	158	518	6.400	156	512	27
	2½	65	3.016	76.6	2.969	75.4	0.177	4.50	7.930	126	413	8.050	124	407	8.110	123	404	8.230	121	397	20
	3	80	3.524	89.5	3.469	88.1	0.197	5.00	10.300	97	318	10.500	95	312	10.510	95	312	10.710	93	307	16
	4	100	4.524	114.9	4.461	113.3	0.213	5.40	14.500	69	226	14.800	68	223	14.770	68	223	15.070	67	220	12
5	125	5.535	140.6	5.461	138.7	0.213	5.40	17.900	56	184	18.400	54	177	18.210	55	180	18.730	53	174	10	
6	150	6.539	166.1	6.461	164.1	0.213	5.40	21.300	47	154	21.900	46	151	21.700	46	151	22.300	45	148	7	

Tolerances:  
**THICKNESS:** Light Tube -8%, Medium and Heavy Tubes -10%.  
**WEIGHT:** Single Tube +10% -8%, Quantity - 150 metres and above of one size & class ±4%.  
**LENGTH:** 6 metres ±0.05 metres

SHIELD reserves the right to change the contents without notice.

# Shield Pipes

## Seamless & Welded Steel Pipe

to ASTM A53, Grade A & B (Sizes, Dimensions & Weights)



Nominal Pipe Size	O.D.	Schedule 10		Schedule 20		Schedule 30		Standard		Schedule 40		Schedule 60		Schedule 80	
		Inch	mm	Wall	Wt.	Wall	Wt.	Wall	Wt.	Wall	Wt.	Wall	Wt.	Wall	Wt.
3/8	17.1	-	-	-	-	-	-	2.31	0.84	2.31	0.84	-	-	3.20	1.10
1/2	21.3	-	-	-	-	-	-	2.77	1.27	2.77	1.27	-	-	3.73	1.62
3/4	26.7	-	-	-	-	-	-	2.87	1.69	2.87	1.69	-	-	3.91	2.21
1	33.4	-	-	-	-	-	-	3.38	2.50	3.38	2.50	-	-	4.55	3.25
1 1/4	42.2	-	-	-	-	-	-	3.56	3.39	3.56	3.39	-	-	4.85	4.47
1 1/2	48.3	-	-	-	-	-	-	3.68	4.05	3.68	4.05	-	-	5.08	5.39
2	60.3	-	-	-	-	-	-	3.91	5.44	3.91	5.44	-	-	5.54	7.48
2 1/2	73.0	-	-	-	-	-	-	5.16	8.63	5.16	8.63	-	-	7.01	11.41
3	88.9	-	-	-	-	-	-	5.49	11.29	5.49	11.29	-	-	7.62	15.27
3 1/2	101.6	-	-	-	-	-	-	5.74	13.57	5.74	13.57	-	-	8.08	18.63
4	114.3	-	-	-	-	-	-	6.02	16.07	6.02	16.07	-	-	8.56	22.32
5	141.3	-	-	-	-	-	-	6.55	21.77	6.55	21.77	-	-	9.52	30.94
6	168.3	-	-	-	-	-	-	7.11	28.26	7.11	28.26	-	-	10.97	42.56
8	219.1	-	-	6.35	33.31	7.04	36.31	8.18	42.55	8.18	42.55	10.31	53.08	12.70	64.64
10	273.0	-	-	6.35	41.75	7.80	51.01	9.27	60.29	9.27	60.29	12.70	81.52	15.09	95.97
12	323.8	-	-	6.35	49.71	8.38	65.18	9.52	73.78	10.31	79.70	14.27	108.92	17.48	132.04
14	355.6	6.35	54.69	7.92	67.90	9.52	81.25	9.52	81.25	11.13	94.55	15.09	126.71	19.05	158.10
16	406.4	6.35	62.64	7.92	77.83	9.52	93.17	9.52	93.17	12.70	123.30	16.66	160.12	21.44	203.53
18	457.2	6.35	70.60	7.92	87.75	11.13	122.43	9.52	105.10	14.27	155.87	19.05	205.83	23.83	254.67
20	508.0	6.35	78.55	9.52	117.02	12.70	155.12	9.52	117.02	15.09	183.42	20.62	247.83	26.19	311.17
24	610.0	6.35	94.46	9.52	140.88	14.27	209.50	9.52	140.88	17.48	255.24	24.61	355.02	30.96	441.78
26	660.0	7.92	127.43	12.70	202.85	-	-	9.52	152.80	-	-	-	-	-	-

### Tensile Requirements

	Grade A	Grade B
Tensile Strength, Min, Psi [MPa]	48,000 [330]	60,000 [415]
Yield Strength, Min, Psi [MPa]	30,000 [205]	35,000 [240]

SHIELD reserves the right to change the contents without notice.

Wall = Wall thickness in mm  
Wt. = Weight in Kg/m.

Available in black & hot dipped galvanized

\* UL & FM details are available in their respective certificates.

NOTE: Hydrostatic pressure test applied as per ASTM Standards.





# Threaded Fittings

For HVAC & Fire Fighting Applications

NOTE: Refer to UL/FM certificates for more information.

# Shield Threaded Fittings

Shield Threaded Fittings feature a complete range of ductile iron / malleable iron threaded fittings in a wide variety of configurations in sizes from 1/2" to 6".

Shield fittings are UL, ULC listed and FM approved for water line and fire protection applications.

<b>Material</b>	Ductile iron ASTM A536, BS EN 1563 Malleable Iron BS EN 1562
<b>Max. Working Pressure</b>	500 Psi
<b>Dimensions</b>	American Standard ASME B16.3, B16.4, Unions B16.39 British Standard BS EN 10242, BS 143 & 1256
<b>Threads</b>	American Standard ANSI B1.20.1 British Standard BS 21, ISO 7/1 (Taper)
<b>Finish</b>	Black or hot dipped galvanized



# Shield Threaded Fittings

## SDT-100 Elbow 90°

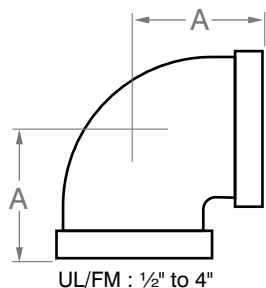

Nominal Size	A
Inch	Inch
1/2	1.12
3/4	1.31
1	1.50
1 1/4	1.75
1 1/2	1.95
2	2.25

Nominal Size	A
Inch	Inch
2 1/2	2.70
3	3.08
3 1/2	3.42
4	3.79
5	4.50
6	5.13

## SDT-101 Reducing Elbow 90°

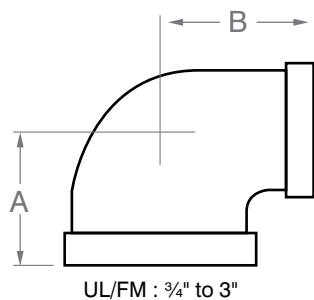

Nominal Size	A	B
Inch	Inch	Inch
3/4 x 1/2	1.20	1.22
1 x 1/2	1.26	1.36
1 x 3/4	1.37	1.45
1 1/4 x 1/2	1.34	1.53
1 1/4 x 3/4	1.45	1.62
1 1/4 x 1	1.58	1.67
1 1/2 x 1/2	1.41	1.66
1 1/2 x 3/4	1.52	1.75
1 1/2 x 1	1.65	1.80
1 1/2 x 1 1/4	1.82	1.88
2 x 3/4	1.60	1.97
2 x 1	1.73	2.02
2 x 1 1/2	2.02	2.16
2 1/2 x 2	2.39	2.60
2 1/2 x 1 1/2	2.16	2.51
3 x 2 1/2	2.83	3.00
3 x 2	2.52	2.89
4 x 3	3.30	3.60

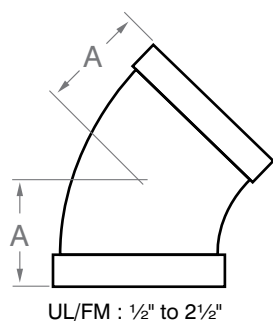

## SDT-200 Elbow 45°

Nominal Size	A
Inch	Inch
1/2	0.88
3/4	0.98
1	1.12
1 1/4	1.29
1 1/2	1.43
2	1.68

Nominal Size	A
Inch	Inch
2 1/2	1.95
3	2.17
3 1/2	2.39
4	2.61
5	3.05
6	3.46

- Refer to UL/FM certificates for more information.
- SHIELD reserves the right to change the contents without notice.

# Shield Threaded Fittings

## SDT-12 Tee

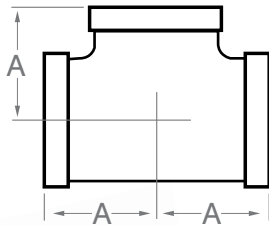

UL/FM: 1/2" to 4"

Nominal Size Inch	A Inch
1/2	1.12
3/4	1.31
1	1.50
1 1/4	1.75
1 1/2	1.95
2	2.25

Nominal Size Inch	A Inch
2 1/2	2.70
3	3.08
3 1/2	3.42
4	3.79
5	4.50
6	5.13

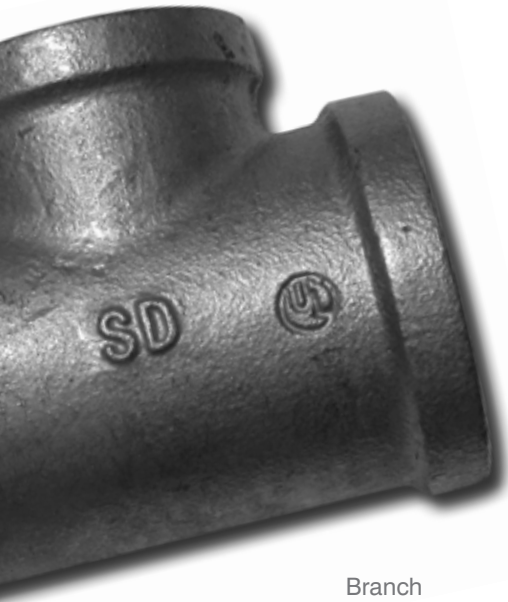

## SDT-53 Reducing Tee

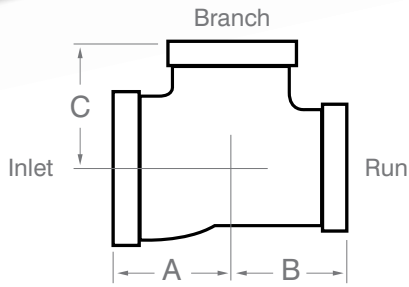

UL/FM: 3/4" to 2 1/2"

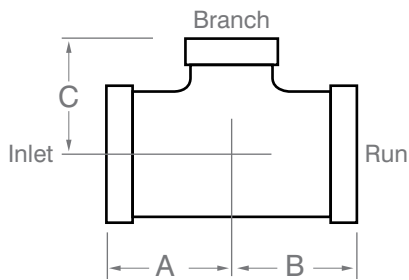

UL/FM: 3/4" to 3"

Nominal Size			A	B	C	
Inlet Inch	Run Inch	Branch Inch	Inch	Inch	Inch	
1/2	3/4	1/2	1.20	1.20	1.22	
1	1	1	1.50	1.36	1.50	
		1/2	1.26	1.20	1.36	
	3/4	3/4	1.37	1.31	1.45	
		1	1.50	1.45	1.50	
1 1/4	1	1/2	1.26	1.26	1.36	
		3/4	1.37	1.37	1.45	
		1	1.58	1.50	1.67	
	1 1/4	1/2	1.34	1.26	1.53	
		3/4	1.45	1.37	1.62	
		1	1.75	1.67	1.75	
1 1/2	1	1/2	1.34	1.34	1.53	
		3/4	1.45	1.45	1.62	
		1	1.58	1.58	1.67	
		1 1/4	1.75	1.67	1.75	
	1 1/4	1/2	1.44	1.31	1.69	
		3/4	1.50	1.37	1.75	
		1	1.65	1.50	1.80	
		1 1/2	1.94	1.80	1.94	
	1 1/2	1/2	1.41	1.34	1.66	
		3/4	1.52	1.45	1.75	
		1	1.65	1.58	1.80	
		1 1/4	1.82	1.82	1.88	
2	1	1/2	1.41	1.41	1.66	
		3/4	1.52	1.52	1.75	
	1 1/4	1	1.65	1.65	1.80	
		1 1/2	1.82	1.82	1.88	
	2	1	2.25	2.02	2.25	
		1 1/4	2	2.25	2.10	2.25
		1 1/2	1/2	1.49	1.41	1.88
			3/4	1.60	1.52	1.97
2 1/2	1 1/2	1	1.73	1.65	2.02	
		1 1/2	2.02	1.94	2.16	
	2	2	2.25	2.16	2.25	
		1/2	1.49	1.49	1.88	
	2	3/4	1.60	1.60	1.97	
		1	1.73	1.73	2.02	
2 1/2	1 1/4	1.90	1.90	2.10		
	1 1/2	2.02	2.02	2.16		
2 1/2	2	3/4	1.74	1.60	2.32	

Note: Sizes available upto 6" x 6" x 2"

• Refer to UL/FM certificates for more information.

• SHIELD reserves the right to change the contents without notice.

# Shield Threaded Fittings

## SDT-30 Reducing Coupling

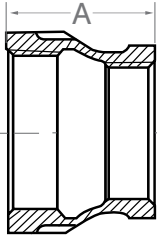

UL/FM: 1/2" to 1 1/2"

Nominal Size Inch	A Inch
3/4 x 1/2	1.52
1 x 1/2	1.67
1 x 3/4	1.67
1 1/4 x 3/4	1.93
1 1/4 x 1	1.93
1 1/2 x 1	2.18

Nominal Size Inch	A Inch
1 1/2 x 1 1/4	2.18
2 x 1	2.53
2 x 1 1/4	2.53
2 x 1 1/2	2.53
2 1/2 x 2	2.68

Note: Sizes available up to 6"

## SDT-13 Cross

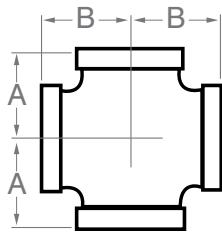

UL/FM : 1" to 2"

Nominal Size Inch	A Inch	B Inch
1/2	1.12	1.12
1	1.50	1.50
1 1/4	1.75	1.75
1 1/2	1.95	1.95
2	2.25	2.25
2 1/2	2.70	2.70
3	3.08	3.08
3 1/2	3.42	3.42
4	3.79	3.79
5	4.50	4.50
6	5.13	5.13

## SDT-51 Reducing Cross

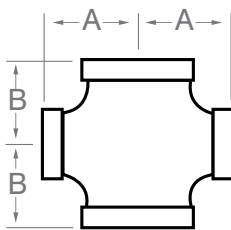

UL/FM : 1 1/4" to 2"

Nominal Size Inch	A Inch	B Inch
1 1/4 x 1 1/4 x 1 x 1	1.67	1.58
1 1/2 x 1 1/2 x 1 x 1	1.80	1.65
2 x 2 x 1 x 1	2.02	1.73
2 1/2 x 2 1/2 x 2 x 2	2.37	2.60
3 x 3 x 2 x 2	2.52	2.89

• Refer to UL/FM certificates for more information.  
• SHIELD reserves the right to change the contents without notice.



# Factory Mutual System



## Shield Threaded Fittings

### SDT-22 Straight Coupling

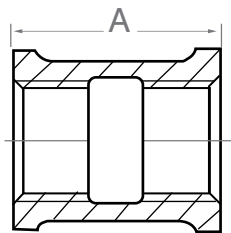

UL/FM : ½" to 2½"

Nominal Size Inch	A Inch
½	1.34
¾	1.52
1	1.67
1¼	1.93
1½	2.18

Nominal Size Inch	A Inch
2	2.53
2½	2.68
3	3.18
4	3.69

### SDT-55 Plug

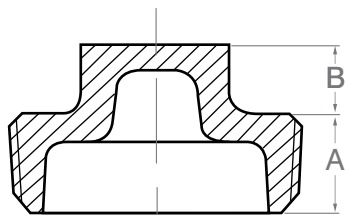

UL/FM : ½" to 2"

Nominal Size Inch	A Inch	B Inch
½	0.56	0.38
¾	0.63	0.44
1	0.75	0.50
1¼	0.80	0.56
1½	0.83	0.62
2	0.88	0.58
2½	1.07	0.74
3	1.13	0.80
3½	1.18	0.86

Note: Sizes available up to 6"

### SDT-14 Cap

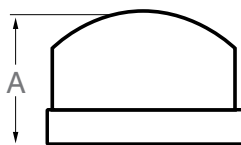

UL/FM : ½" to 2½"

Nominal Size Inch	A Inch
½	0.87
¾	0.97
1	1.16
1¼	1.28
1½	1.33

Nominal Size Inch	A Inch
2	1.45
2½	1.70
3	1.80
4	2.08
6	2.55

• Refer to UL/FM certificates for more information.  
• SHIELD reserves the right to change the contents without notice.



# Shield Threaded Fittings

## SDT-22 Straight Coupling

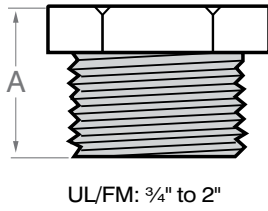

Nominal Size	A
Inch	Inch
1 x 1/2	1.06
1 x 3/4	1.06
1 1/4 x 1	1.18
1 1/2 x 1	1.26
1 1/2 x 1 1/4	1.26
2 x 1	1.34
2 x 1 1/4	1.34
2 x 1 1/2	1.34

## SDT-59 Union

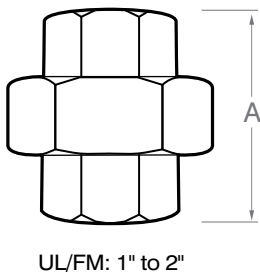

Nominal Size	A
Inch	Inch
1/2	1.72
3/4	1.94
1	2.06
1 1/4	2.26
1 1/2	2.41
2	2.75
2 1/2	3.22
3	3.50
4	3.85

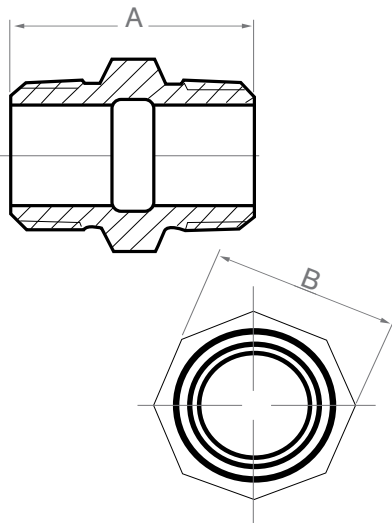

## SDT-11 Hex Nipple

Nominal Size	A	B
Inch	Inch	Inch
1/2	1.57	0.98
3/4	1.77	1.18
1	2.05	1.45
1 1/4	2.20	1.81
1 1/2	2.28	2.05
2	2.56	2.52
2 1/2	2.83	3.15
3	3.15	3.70
4	3.62	4.65

## SDT-111 Hex Reducing Nipple

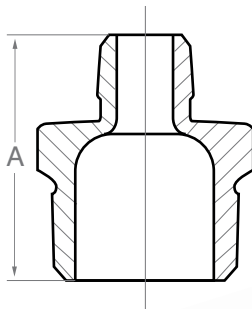

Nominal Size	A
Inch	Inch
1/4 x 1/8	31.00
1/4 x 3/4	54.00
1 1/4 x 1/2	57.00
2 x 1 1/2	68.00
2 1/2 x 1	75.00
2 1/2 x 1 1/4	75.00
2 1/2 x 1 1/2	75.00
2 1/2 x 2	75.00
3 x 1 1/2	83.00
3 x 2	83.00
3 x 2 1/2	83.00

• Refer to UL/FM certificates for more information.  
 • SHIELD reserves the right to change the contents without notice.

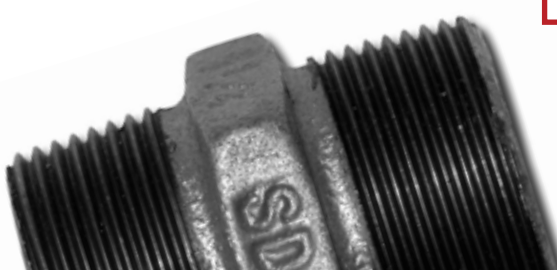



# Grooved Fittings

for Fire Fighting, HVAC, Oil & Gas Projects



# Shield Grooved Fittings



**The Shield Grooved System** provides an economical and efficient piping system solution and offers significant benefits when compared to conventional types of pipe connections including:

- Faster Installation
- Because there is no need for welding or heating, the Shield System ensures a safer and reliable working environment
- Ensures easy alignment
- Reduces noise and vibration
- Easy to install and remove in case of any maintenance requirements

Feature a wide range of coupling and fittings for piping applications in Air Conditioning, Fire Fighting Systems and water pipe lines etc...

Shield Grooved Systems offer 3 types of couplings:

High Pressure Couplings (Flexible) • Medium Pressure Couplings (Rigid, Flexible) • Light Pressure Couplings (Rigid, Flexible)

## Material

Shield Grooved Coupling housing and other grooved fittings are cast from Ductile Iron to ASTM A536 Grade 65-45-12 in red paint or hot dipped galvanized, bolts are carbon steel to ISO 898-1 class 8.8 heat treated, hot dipped galvanized nuts and bolt can also be supplied upon request.

## Gasket (C shaped)

Shield Grooved Coupling are available in various types of gasket.

Coupling with EPDM rubber gasket are widely used around the world and it conforms to ASTM D2000-1, Grade A.

It is important to use the gasket that suits your application, use the table below to select the optimum gasket.

Material	Temperature Range	Colour	General Recommended Application
EPDM	-34° C ~ +110° C	Green Strip	Hot water service, variety of diluted acid, oil free air, chemical. This is NOT recommended for Petroleum services.
Nitrile	-29° C ~ +82° C	Orange Strip	Petroleum products, vegetable and mineral oils, air with oil vapours. This is NOT recommended for hot water +66°C or for hot dry air over +60°C.
Silicone	-34° C ~ +177° C	Red Gasket	Dry heat and air without hydrocarbons up to +177°C and certain chemicals.

*SHIELD Grooved Coupling EPDM Gaskets must be lubricated on the lips and outside back prior to assembly using silicon based non-petroleum lubricant.*

*Shield Grooved Red Paint fittings are recommended to use for indoor applications, in normal condition galvanized grooved fittings can be used for outdoor application, however, considering the atmosphere further coating protection may need to apply according to the project requirement. For more details about lubricant for other types of gasket, please contact us.*

# Shield Rigid Coupling

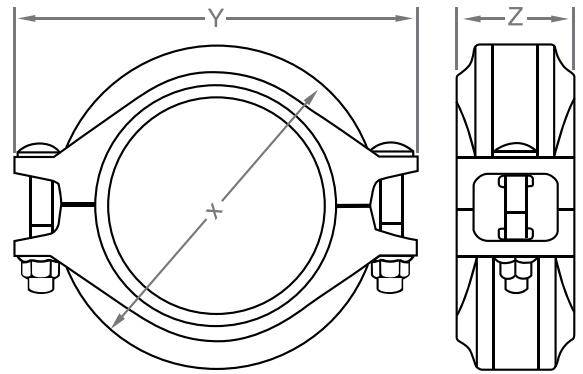

## SDG-22 Standard

Nominal Size	Pipe O.D.	Maximum Working Pressure	Dimensions			Bolt/Nut No. - Size
			X mm	Y mm	Z mm	
Inch	mm	Psi				mm
1	33.4	500	59.0	100.0	44.0	2 <sup>3</sup> / <sub>8</sub> x 55
1 <sup>1</sup> / <sub>4</sub>	42.2	500	66.0	105.0	45.1	2 <sup>3</sup> / <sub>8</sub> x 55
1 <sup>1</sup> / <sub>2</sub>	48.3	500	72.0	110.0	45.5	2 <sup>3</sup> / <sub>8</sub> x 55
2	60.3	500	86.0	132.5	46.5	2 <sup>3</sup> / <sub>8</sub> x 55
2 <sup>1</sup> / <sub>2</sub>	73.0	500	99.0	154.0	46.5	2 <sup>1</sup> / <sub>2</sub> x 60
3 O.D.	76.1	500	102.5	152.5	46.5	2 <sup>1</sup> / <sub>2</sub> x 70
3	88.9	500	117.0	168.5	46.5	2 <sup>1</sup> / <sub>2</sub> x 75
4	114.3	500	148.0	200.0	52.5	2 <sup>1</sup> / <sub>2</sub> x 75
5 <sup>1</sup> / <sub>2</sub> O.D.	139.7	500	172.0	235.0	52.5	2 <sup>5</sup> / <sub>8</sub> x 85
5	141.3	500	172.0	231.5	52.5	2 <sup>5</sup> / <sub>8</sub> x 85
6 <sup>1</sup> / <sub>2</sub> O.D.	165.1	500	199.5	267.5	53.5	2 <sup>5</sup> / <sub>8</sub> x 85
6	168.3	500	203.0	271.5	53.5	2 <sup>5</sup> / <sub>8</sub> x 85
8	219.1	450	246.5	350.0	61.5	2 <sup>3</sup> / <sub>4</sub> x 115
10	273.0	300	333.0	428.0	63.0	2 <sup>3</sup> / <sub>4</sub> x 115
12	323.9	300	390.0	470.0	63.0	2 <sup>7</sup> / <sub>8</sub> x 140
14	355.6	300	415.0	510.0	72.0	3 <sup>7</sup> / <sub>8</sub> x 140
16	406.4	300	468.0	575.0	72.0	3 <sup>7</sup> / <sub>8</sub> x 140
18	457.2	225	508.0	608.0	78.0	3 <sup>7</sup> / <sub>8</sub> x 140
20	508.0	225	563.0	660.0	78.0	4 <sup>7</sup> / <sub>8</sub> x 140
24	610.0	225	668.0	772.0	78.0	4-1 x 140

- SHIELD reserves the right to change the contents without notice.
- Refer to UL/FM certificates for more information.

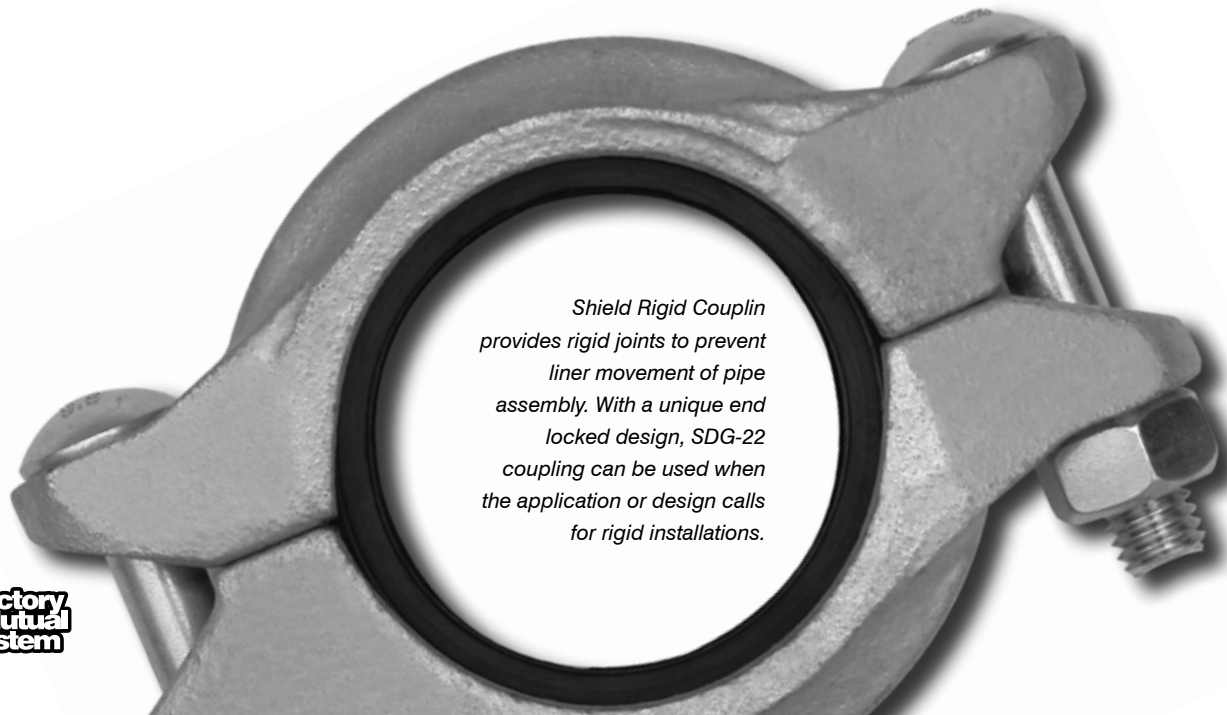

*Shield Rigid Coupling provides rigid joints to prevent liner movement of pipe assembly. With a unique end locked design, SDG-22 coupling can be used when the application or design calls for rigid installations.*

# Shield Light Rigid Coupling

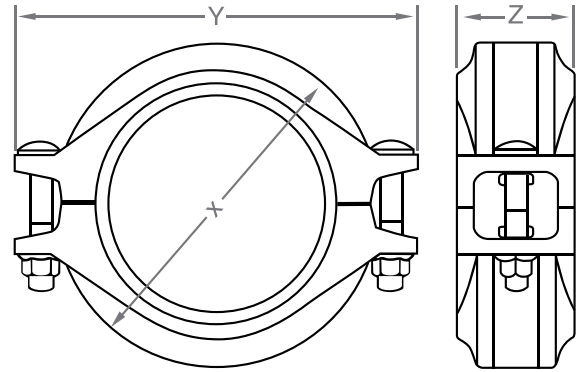

## SDG-20

Nominal Size	Pipe O.D.	Maximum Working Pressure	Dimensions			Bolt/Nut No. - Size
			X mm	Y mm	Z mm	
Inch	mm	Psi				mm
3	88.9	350	114.0	160.0	45.0	2½ x 55
4	114.3	350	140.0	192.0	46.5	2½ x 70
5½ O.D.	139.7	350	168.0	225.0	50.0	2½ x 75
5	141.3	350	170.0	225.0	50.0	2½ x 75
6½ O.D.	165.1	350	195.0	250.0	50.0	2½ x 75
6	168.3	350	200.0	255.0	50.0	2½ x 75
8	219.1	350	255.0	324.0	58.0	2½ x 85
10	273.0	300	318.0	410.0	63.0	2¾ x 120

# Shield Flexible Coupling

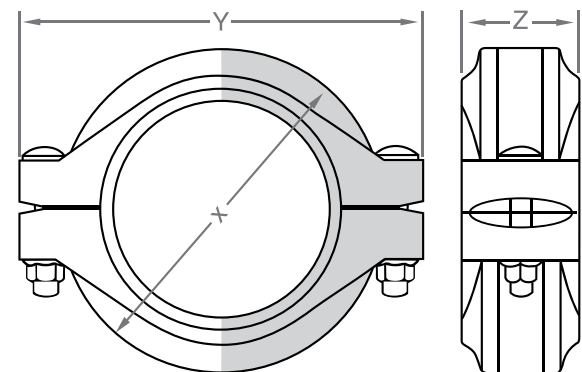

## SDG-27 Heavy Duty

Nominal Size	Pipe O.D.	Maximum Working Pressure	Dimensions			Bolt/Nut No. - Size
			X mm	Y mm	Z mm	
Inch	mm	Psi				mm
2	60.3	750	91.0	133.0	46.5	2½ x 75
2½	73.0	750	104.0	165.0	46.5	2½ x 75
3 O.D.	76.1	750	107.0	165.0	46.5	2½ x 75
3	88.9	750	122.0	171.0	47.0	2½ x 75
4	114.3	750	151.5	213.0	52.0	2½ x 85
5	141.3	750	182.0	241.0	52.0	2¾ x 115
6½ O.D.	165.1	750	208.0	281.0	52.0	2¾ x 115
6	168.3	750	210.0	286.0	52.0	2¾ x 115
8	219.1	750	268.0	354.0	62.0	2½ x 140

Shield SDG-27 is a high pressure flexible coupling can be used in different applications where high pressure service is required.

• SHIELD reserves the right to change the contents without notice.  
• Refer to UL/FM certificates for more information.





# Shield Flexible Coupling

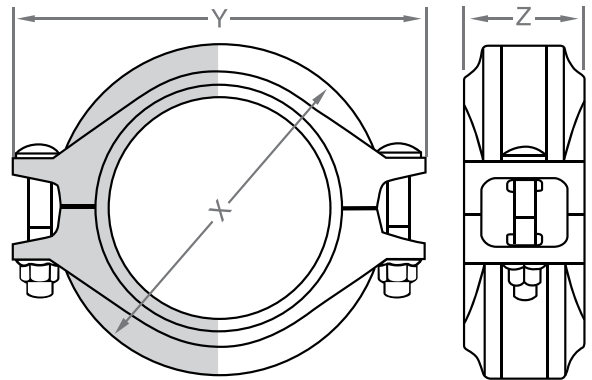

## SDG-25 Standard

*Shield Flexible Couplings allow controlled angular movement of the pipe to assist alignment and installation. The advantage of flexibility must be considered in the design or hanger and support spacing.*

Nominal Size	Pipe O.D.	Maximum Working Pressure	Dimensions			Bolt/Nut No. - Size
			X	Y	Z	
Inch	mm	Psi	mm	mm	mm	mm
1¼	42.2	500	66.5	103.0	45.5	2¾ x 55
1½	48.3	500	72.0	108.0	45.0	2¾ x 55
2	60.3	500	84.0	129.0	45.0	2¾ x 55
2½	73.0	500	101.0	142.0	45.5	2¾ x 55
3 O.D	76.1	500	102.0	147.0	45.5	2¾ x 55
3	88.9	500	116.0	163.5	45.5	2½ x 75
4	114.3	500	145.0	197.0	50.0	2½ x 75
5½ O.D	139.7	500	169.0	237.5	51.0	2½ x 80
5	141.3	500	169.0	230.0	51.0	2½ x 80
6½ O.D	165.1	500	196.5	261.5	51.0	2½ x 85
6	168.3	500	201.0	268.0	51.0	2½ x 85
8	219.1	450	260.5	349.5	58.5	2¾ x 115
10	273.0	300	318.0	395.0	65.0	2¾ x 120
12	323.9	300	368.7	458.2	65.0	2¾ x 140
14	355.6	300	402.0	493.0	72.0	3¾ x 140
16	406.4	300	458.0	547.0	72.0	3¾ x 140
18	457.2	300	505.0	598.0	78.0	3¾ x 140
20	508.0	300	550.0	648.0	78.0	4¾ x 140
24	610.0	300	662.0	774.0	78.0	4-1 x 140

• SHIELD reserves the right to change the contents without notice.  
• Refer to UL/FM certificates for more information.





# Shield Light Flexible Coupling

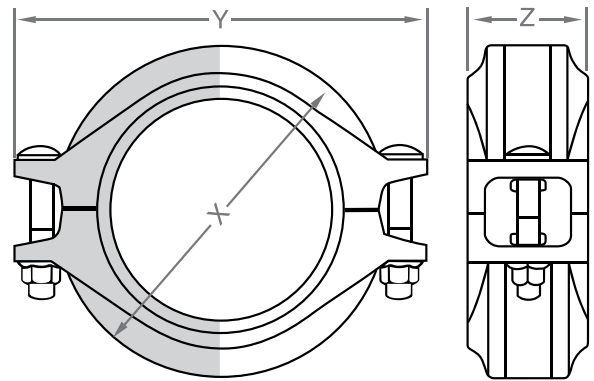

## SDG-21

*SDG-21 is designed for a maximum working pressure of 300psi.*

*The flexibility benefits of this coupling can be used in applications where high pressure is not required.*

Nominal Size	Pipe O.D.	Maximum Working Pressure	Dimensions			Bolt/Nut No. - Size
			X mm	Y mm	Z mm	
4	114.3	300	139.0	182.0	50.0	2 <sup>3</sup> / <sub>8</sub> x 58
5 <sup>1</sup> / <sub>2</sub> O.D.	139.7	450	168.0	228.0	51.0	2 <sup>5</sup> / <sub>8</sub> x 80
6 <sup>1</sup> / <sub>2</sub> O.D.	165.1	300	192.0	244.0	51.0	2 <sup>1</sup> / <sub>2</sub> x 75
6	168.3	300	200.0	266.0	52.0	2 <sup>5</sup> / <sub>8</sub> x 85
10	273.0	300	320.0	398.0	64.0	2 <sup>3</sup> / <sub>4</sub> x 120

- SHIELD reserves the right to change the contents without notice.
- Refer to UL/FM certificates for more information.





# Shield Reducing Coupling

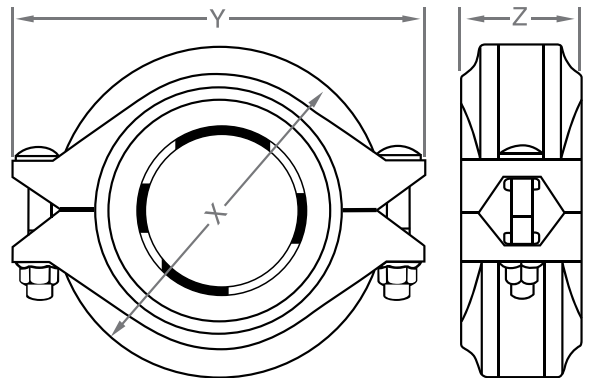

## SDG-30

*Shield's SDG-30 Reducing Coupling allows in line reduction of the pipe diameter on a piping run. SDG-30 can also replace the need for two couplings as well as reducing fittings.*

Nominal Size	Pipe O.D.	Maximum Working Pressure	Dimensions			Bolt/Nut No. - Size
			X	Y	Z	
Inch	mm	Psi	mm	mm	mm	mm
2 x 1½	60.3 x 48.3	300	86.0	125	44.0	2¾ x 55
2½ x 2	73.0 x 60.3	300	100.0	138	45.0	2¾ x 55
3 O.D. x 2	76.1 x 60.3	300	102.0	144	45.0	2¾ x 55
3 x 2	88.9 x 60.3	300	115.0	168	46.0	2½ x 70
3 x 2½	88.9 x 73.0	300	115.0	168	46.0	2½ x 70
3 x 3 O.D.	88.9 x 76.1	300	115.0	172	46.0	2½ x 70
4 x 2	114.3 x 60.3	300	144.0	198	50.0	2½ x 70
4 x 2½	114.3 x 73.0	300	144.0	198	50.0	2½ x 70
4 x 3 O.D.	114.3 x 76.1	300	144.0	202	50.0	2½ x 70
4 x 3	114.3 x 88.9	300	148.0	198	50.0	2½ x 70
6½ O.D. x 3	165.1 x 88.9	300	200.0	260	51.0	2¾ x 115
6½ O.D. x 4	165.1 x 114.3	300	197.0	260	51.0	2¾ x 85
6 x 3	168.3 x 88.9	300	200.0	268	51.0	2¾ x 85
6 x 4	168.3 x 114.3	300	202.5	268	52.5	2¾ x 85
8 x 6½ O.D.	219.1 x 165.1	300	257.0	335	60.0	2¾ x 115
8 x 6	219.1 x 168.3	300	260.0	338	60.0	2¾ x 115

• SHIELD reserves the right to change the contents without notice.  
• Refer to UL/FM certificates for more information.

# Shield Angle Pad Coupling

## SDG-24

Nominal Size	Pipe O.D.	Maximum Working Pressure	Dimensions			Bolt/Nut No. - Size
			X mm	Y mm	Z mm	
Inch	mm	Psi				mm
1¼	42.4	500	64.0	99.0	46.5	2-M10 x 55
1½	48.3	500	70.0	105.0	46.5	2-M10 x 55
2	60.3	500	85.0	121.0	46.5	2-M10 x 55
2½	73.0	500	99.0	134.0	47.5	2-M10 x 63
3 O.D.	76.1	300	102.0	137.0	47.5	2-M10 x 63
3	88.9	500	115.0	150.0	47.5	2-M10 x 60
4	114.3	500	142.0	180.0	50.0	2-M10 x 65
5½ O.D.	139.7	300	171.0	214.0	52.5	2-M12 x 75
6½ O.D.	165.1	300	198.0	242.0	52.5	2-M12 x 75
6	168.3	300	201.0	245.0	52.5	2-M12 x 75
8	219.1	300	258.0	331.0	63.5	2-M20 x 110
10	273.0	300	321.0	406.0	64.5	2-M22 x 140

SHIELD reserves the right to change the contents without notice.  
• Refer to UL/FM certificates for more information.

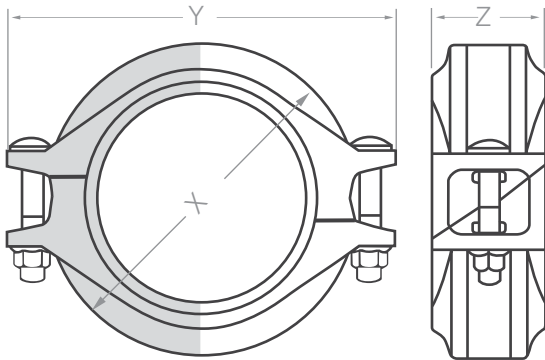



# Shield 90° & 45° Elbows

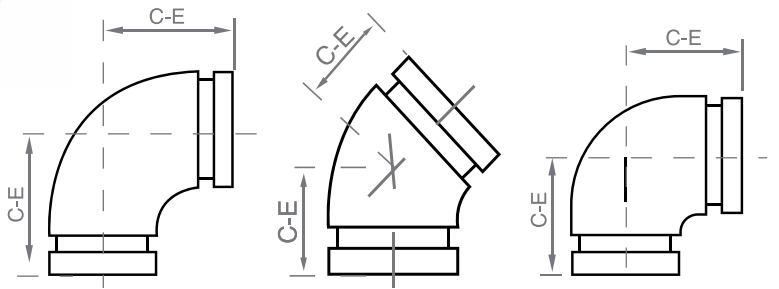

90° SDG-100, 45° SDG-200, SDG° SDG-105

Nominal Size	Pipe O.D.	SDG-100		SDG-200		SDG-105	
		90° Elbow Dimensions		45° Elbow Dimensions		90° Elbow Dimensions	
Inch	mm	Maximum Working Pressure PSI	C-E mm	Maximum Working Pressure PSI	C-E mm	Maximum Working Pressure PSI	C-E mm
1	33.4	500	57.0	500	38.0	-	-
1¼	42.2	500	70.0	500	44.0	-	-
1½	48.3	500	70.0	500	44.0	-	-
2	60.3	500	82.5	500	51.0	300	70.00
2½	73.0	500	95.0	500	57.0	300	76.00
3 O.D.	76.1	500	101.5	500	57.0	300	76.00
3	88.9	500	108.0	500	64.0	300	85.50
4	114.3	500	127.0	500	76.0	300	101.00
5½ O.D.	139.7	500	140.0	500	82.5	300	101.00
5	141.3	500	140.0	500	83.0	300	124.00
6½ O.D.	165.1	500	165.0	500	89.0	300	140.00
6	168.3	500	165.0	500	89.0	300	140.00
8	219.1	500	197.0	500	108.0	300	175.00
10	273.0	500	229.0	500	120.0	-	-
12	323.9	500	254.0	500	133.0	-	-
14	355.6	300	279.0	300	152.0	-	-
16	406.4	300	305.0	300	184.0	-	-
18	457.2	300	394.0	300	203.0	-	-

• SHIELD reserves the right to change the contents without notice.  
• Refer to UL/FM certificates for more information.

# Shield 22.5° & 11.25° Elbows

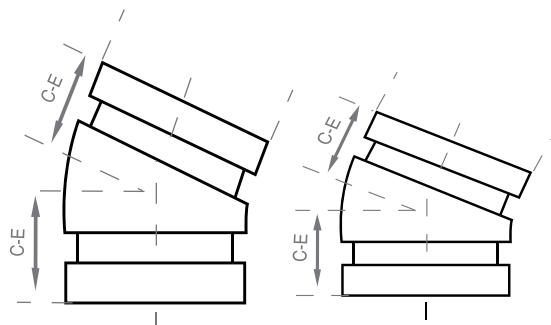

## 22.5° SDG-225 & 11.25° SDG-112

Nominal Size	Pipe O.D.	Maximum Working Pressure	22.5° Elbow Dimensions	11.25° Elbow Dimensions
			C-E mm	C-E mm
1¼	42.4	500	45.0	35.0
1½	48.3	500	45.0	35.0
2	60.3	500	48.0	35.0
2½	73.0	500	51.0	38.0
3 O.D.	76.1	500	51.0	38.0
3	88.9	500	57.0	38.0
4	114.3	500	73.0	44.0
5½ O.D.	139.7	500	73.0	51.0
6½ O.D.	165.1	500	79.0	51.0
6	168.3	500	79.0	51.0
8	219.1	500	98.0	51.0

• SHIELD reserves the right to change the contents without notice.  
• Refer to UL/FM certificates for more information.



# Factory Mutual System



# Shield Tees

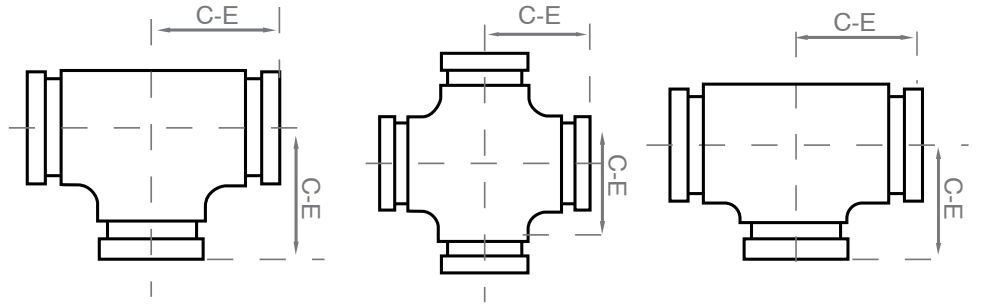

## SDG-12 Tee, SDG-13 Cross Tee, SDG-102 Tee

Nominal Size	Pipe O.D.	Maximum Working Pressure	SDG-12 Tee Dimensions	SDG-13 Cross Tee Dimensions	SDG-102 Tee (Short) Dimensions	
			C-E	C-E	Maximum Working Pressure	C-E
Inch	mm	PSI	mm	mm	Psi	mm
1	33.4	500	57.0	-	-	-
1¼	42.4	500	70.0	70.0	-	-
1½	48.3	500	70.0	70.0	-	-
2	60.3	500	82.5	70.0	300	70.0
2½	73.0	500	95.0	76.0	300	76.0
3 O.D.	76.1	500	95.0	76.0	300	76.0
3	88.9	500	108.0	85.5	300	85.5
4	114.3	500	127.0	101.0	300	101.0
5½ O.D.	139.7	500	140.0	124.0	300	124.0
5	141.3	500	140.0	124.0	300	124.0
6½ O.D.	165.1	500	165.0	140.0	300	140.0
6	168.3	500	165.0	140.0	300	140.0
8	219.1	500	197.0	175.0	300	175.0
10	273.0	500	229.0	229.0	-	-
12	323.9	500	254.0	254.0	-	-
14	377.0	300	279.0	279.0	-	-
16	406.4	300	305.0	305.0	-	-
18	457.2	300	342.0	343.0	-	-
20	508.0	300	381.0	381.0	-	-
24	609.6	300	432.0	432.0	-	-

• Reducing cross (grooved, threaded) are also available contact SHIELD for details.

# Shield Cap

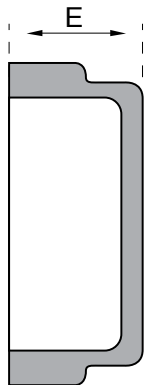

## SDG-14

Nominal Size	Pipe O.D.	Maximum Working Pressure	Cap Dimension
Inch	mm	Psi	E mm
1¼	42.2	500	25.5
1½	48.3	500	25.5
2	60.3	500	25.5
2½	73.0	500	25.5
3 O.D.	76.1	500	25.5
3	88.9	500	25.5
4	114.3	500	27.0
5½ O.D.	139.7	500	27.0
5	141.3	500	27.0
6½ O.D.	165.1	500	27.0
6	168.3	500	27.0
8	219.1	500	30.2
10	273.0	500	32.0
12	323.9	500	32.0

• SHIELD reserves the right to change the contents without notice.  
• Refer to UL/FM certificates for more information.



# Shield Grooved & Adaptor Flanges

Grooved Flange SDG-15  
& Adaptor Flange SDG-16

PN10/PN16

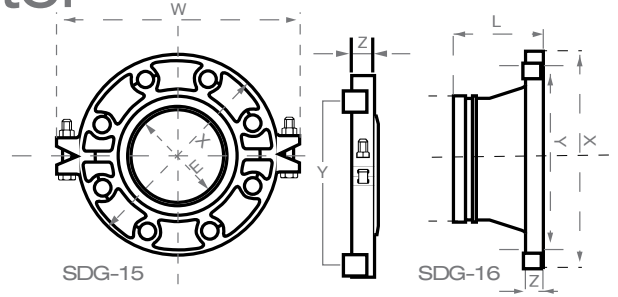

Nominal Size	Pipe O.D.	Max. Working Pressure	Grooved Flange Dimensions							Adaptor Flange Dimensions				
			W	Z	X	Y	E	Bolt/Nut Size		L	X	Y	Z	Bolt/Nut Size
Inch	mm	Psi	mm	mm	mm	mm	mm	mm	mm	mm	mm	mm	mm	mm
1½	48.3	300	195.0	18.5	150	110	45.4	2-M10 x 50	4-M16	60.5	150	110	16	4-M16
2	60.3	300	220.0	18.5	165	125	57.5	2-M10 x 50	4-M16	65.0	165	125	16	4-M16
3 O.D.	76.1	300	235.0	18.5	185	145	72.7	2-M10 x 50	4-M16	65.0	165	145	16	4-M16
3	88.9	300	252.0	18.5	195	160	85.5	2-M10 x 50	8-M16	65.0	200	160	16	8-M16
4	114.3	300	279.0	18.5	224	180	110.5	2-M10 x 50	8-M16	70.0	220	180	16	8-M16
5½ O.D.	139.7	300	320.0	23.0	250	210	135.5	2-M12 x 65	8-M16	70.0	250	210	18	8-M16
6½ O.D.	165.1	300	346.0	21.5	280	240	160.8	2-M12 x 65	8-M20	70.0	285	240	18	8-M20
6	168.3	300	346.0	24.0	280	240	164.3	2-M12 x 65	8-M20	70.0	285	240	18	8-M20
8	219.1	300	414.3	30.0	340	295	214.9	2½ x 70	12-M20	80.0	340	295	19	12-M20
10	273	300	480.0	25.5	405	355	268.9	2½ x 70	12-M24	85.0	405	355	21	12-M24
12	323.9	300	530.5	25.5	460	410	318.9	2½ x 70	12-M24	90.0	460	410	24	12-M24

## ANSI 125/150

Nominal Size	Pipe O.D.	Max. Working Pressure	Grooved Flange Dimensions							Adaptor Flange Dimensions				
			W	Z	X	Y	E	Bolt/Nut Size		L	X	Y	Z	Bolt/Nut Size
Inch	mm	Psi	mm	mm	mm	mm	mm	mm	mm	mm	mm	mm	mm	mm
2	60.3	300	206.0	19.0	152.0	121.0	57.5	2-M10 x 50	4-½	65.0	152.0	120.5	16.0	4-½
2½	73.0	300	-	-	-	-	-	-	-	65.0	185.0	139.7	16.0	4-½
3 O.D.	76.1	300	230.0	19.0	178.0	140.0	72.7	2-M10 x 50	4-½	-	-	-	-	-
3	88.9	300	246.0	19.0	191.0	152.0	85.5	2-M10 x 50	4-½	65.0	200.0	152.4	16.0	8-½
4	114.3	300	280.0	19.0	229.0	191.0	110.5	2-M12 x 55	8-½	70.0	229.0	190.5	16.0	8-½
6	168.3	300	346.0	24.0	280.0	241.3	164.3	2-M12 x 65	8-¾	70.0	282.0	241.3	18.0	8-¾
8	219.1	300	414.3	30.0	341.4	298.5	214.9	2½ x 70	8-¾	75.0	340.0	298.5	19.0	8-¾
10	273.0	300	481.2	30.3	405.6	362.0	268.9	2½ x 70	12-7/8	85.0	406.0	362	21.0	12-7/8
12	323.9	300	553.3	30.4	482.6	431.8	318.9	2½ x 70	12-7/8	-	-	-	-	-
14	355.6	300	590.0	37.0	535.0	476.3	350.6	-	12-1	127.0	535.0	476.3	37.0	12-1
16	406.4	300	650.0	37.0	595.0	539.8	401.5	-	16-1	127.0	595.0	539.8	37.0	12-1
18	457.2	300	690.0	40.0	635.0	577.8	452.2	-	16-11/8	140.0	642.0	577.8	40.0	16-11/8
20	508.0	300	765.0	43.0	700.0	635.0	503.0	-	20-11/8	152.0	700.0	635.0	43.0	20-11/8
24	609.6	300	875.0	49.0	815.0	749.3	601.6	-	20-11/4	152.0	815.0	749.3	49.0	20-11/4

## Class 300

Nominal Size	Pipe O.D.	Grooved Flange Dimensions					
		O.D. of Flange X	I.D. E	Thickness Z	PCD Y	O.D. of Bolt W	Bolt Size
Inch	mm	mm	mm	mm	mm	mm	Inch
2½	73.0	190	69.60	24.6	149.2	244.0	8-¾
3	88.9	210	84.60	28.0	168.3	274.0	8-¾
4	114.3	255	110.20	31.5	200.0	310.0	8-¾
6	168.3	320	164.20	35.5	269.9	388.0	12-¾
8	219.1	380	214.93	41.0	330.2	470.4	12-¾

• SHIELD reserves the right to change the contents without notice.  
• Refer to UL/FM certificates for more information.



# Shield Grooved Reducing Tee

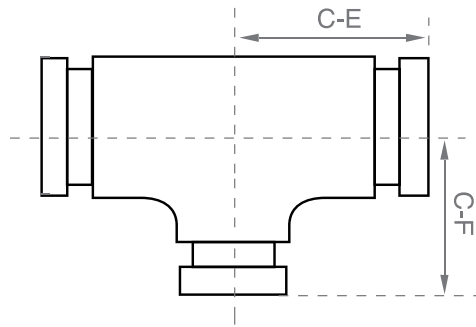

## SDG-53

Nominal Size	Pipe O.D.	Maximum Working Pressure	C-E	C-E
Inch	mm	Psi	mm	mm
2 x 1	60.3 x 33.4	500	70.0	70.0
2 x 1½	60.3 x 48.3	500	70.0	70.0
3 O.D x 2	76.1 x 60.3	500	76.0	76.0
3 x 1	88.9 x 33.4	500	108.0	108.0
3 x 2	88.9 x 60.3	500	85.5	85.5
3 x 3 O.D	88.9 x 76.1	500	85.5	85.5
4 x 1	114.3 x 33.4	500	101.0	101.0
4 x 2	114.3 x 60.3	500	101.0	101.0
4 x 3 O.D	114.3 x 76.1	500	101.0	101.0
4 x 3	114.3 x 88.9	500	101.0	101.0
5½ O.D x 2	139.7 x 60.3	500	124.0	124.0
5½ O.D x 3 O.D	139.7 x 76.1	500	124.0	124.0
5½ O.D x 3	139.7 x 88.9	500	124.0	124.0
5½ O.D x 4	139.7 x 114.3	500	124.0	124.0
5 x 2	141.3 x 60.3	500	124.0	124.0
6½ O.D x 2	165.1 x 60.3	300	140.0	140.0
6½ O.D x 3 O.D	165.1 x 76.1	300	140.0	140.0
6½ O.D x 3	165.1 x 88.9	300	140.0	140.0
6½ O.D x 4	165.1 x 114.3	300	140.0	140.0
6½ O.D x 5½ O.D	165.1 x 139.7	300	140.0	140.0
6 x 2	168.3 x 60.3	500	140.0	140.0
6 x 2½	168.3 x 73.0	500	140.0	140.0
6 x 4	168.3 x 114.3	500	140.0	140.0
6 x 5	168.3 x 141.3	300	140.0	140.0
8 x 2	219.1 x 60.3	500	175.0	175.0
8 x 3 O.D	219.1 x 76.1	300	175.0	175.0
8 x 3	219.1 x 88.9	500	175.0	175.0
8 x 4	219.1 x 114.3	500	175.0	175.0
8 x 5½ O.D	219.1 x 139.7	300	175.0	175.0
8 x 6½ O.D	219.1 x 165.1	300	175.0	175.0
8 x 6	219.1 x 168.3	500	175.0	175.0
10 x 6½ O.D	273.0 x 165.1	300	229.0	229.0
10 x 8	273.0 x 219.1	300	229.0	229.0
12 x 8	323.9 x 219.1	300	254.0	254.0
12 x 10	323.9 x 273.0	300	254.0	254.0
12 x 10	323.9 x 273.0	300	254.0	254.0

• SHIELD reserves the right to change the contents without notice.  
• Refer to UL/FM certificates for more information.

• Reducing tee SDG-55 threaded outlet are also available, contact Shield for details.



# Shield Concentric Reducer

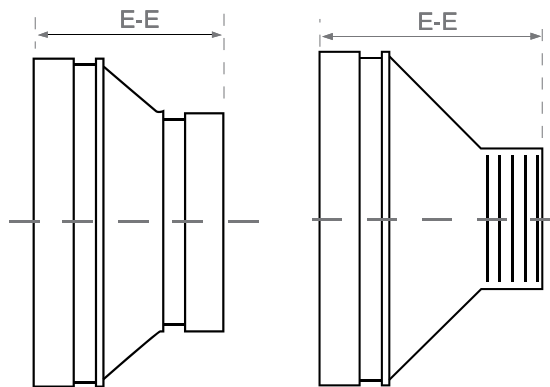

## Grooved SDG-35 & Threaded SDG-37

Nominal Size	Pipe O.D.	Maximum Working Pressure	SDG-35 Grooved Dimensions	SDG-37 Threaded Dimensions
Inch	mm	Psi	E-E mm	E-E mm
2 x 1¼	60.3 x 42.2	500	64	64
2 x 1½	60.3 x 48.3	500	64	64
2½ x 2	73.0 x 60.3	500	64	64
3 O.D x 2	76.1 x 60.3	500	64	64
3 x 1	88.9 x 33.4	500	64	64
3 x 1½	88.9 x 48.3	500	64	64
3 x 2	88.9 x 60.3	500	64	64
3 x 2½	88.9 x 73.0	500	64	64
3 x 3 O.D	88.9 x 76.1	500	64	64
4 x 1¼	114.3 x 42.2	500	76	76
4 x 1½	114.3 x 48.3	500	76	76
4 x 2	114.3 x 60.3	500	76	76
4 x 2½	114.3 x 73.0	500	76	76
4 x 3 O.D	114.3 x 76.1	500	76	76
4 x 3	114.3 x 88.9	500	76	76
5½ O.D x 2	139.7 x 60.3	500	102	102
5½ O.D x 3 O.D	139.7 x 76.1	500	102	102
5½ O.D x 3	139.7 x 88.9	500	102	102
5½ O.D x 4	139.7 x 114.3	500	102	102
6½ O.D x 2	165.1 x 60.3	500	102	102
6½ O.D x 3 O.D	165.1 x 76.1	500	102	102
6½ O.D x 3	165.1 x 88.9	500	102	102
6½ O.D x 4	165.1 x 114.3	500	102	102
6½ O.D x 5½ O.D	165.1 x 139.7	500	102	102
6 x 2	168.3 x 60.3	500	102	102
6 x 2½	168.3 x 73.0	500	102	102
6 x 3 O.D	168.3 x 76.1	500	102	102
6 x 3	168.3 x 88.9	500	102	102
6 x 4	168.3 x 114.3	500	102	102
6 x 5½ O.D	168.3 x 139.7	500	102	102
6 x 5	168.3 x 141.3	500	102	102

- SHIELD reserves the right to change the contents without notice.
- Refer to UL/FM certificates for more information.



# Shield Concentric Reducer (Continued)



## Grooved SDG-35 & Threaded SDG-37

Nominal Size	Pipe O.D.		Maximum Working Pressure	SDG-35 Grooved Dimensions	SDG-37 Threaded Dimensions
	Inch	mm		E-E mm	E-E mm
8 x 2½	219.1 x 73.0	500	127	127	
8 x 3	219.1 x 88.9	500	127	127	
8 x 4	219.1 x 114.3	500	127	127	
8 x 5½ O.D.	219.1 x 139.7	500	127	127	
8 x 5	219.1 x 141.3	500	127	127	
8 x 6½ O.D.	219.1 x 165.1	500	127	127	
8 x 6	219.1 x 168.3	500	127	127	
10 x 6½ O.D.	373.0 x 165.1	500	152	152	
10 x 8	273.0 x 219.1	500	152	152	
12 x 8	323.9 x 219.1	500	178	178	
12 x 10	323.9 x 273.0	500	178	178	
16 x 12	406.4 x 323.9	300	229	229	
16 x 14	406.4 x 355.6	300	229	229	
18 x 14	457.2 x 355.6	300	241	241	
18 x 16	457.2 x 406.4	300	241	241	

# Shield Grooved Eccentric Reducer

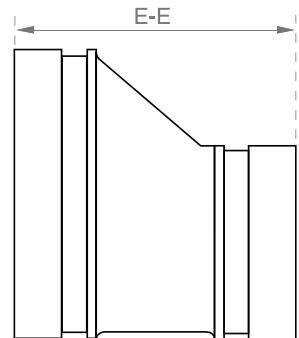

## Grooved SDG-33

Nominal Size Grooved x Grooved	Pipe O.D.		Maximum Working Pressure	SDG-33 Grooved Dimensions
	Inch	mm		E-E mm
4 x 3 O.D.	114.3 x 76.1	500	102	
4 x 3	114.3 x 88.9	500	102	
5½ O.D x 4	139.7 x 114.3	500	127	
6½ O.D x 3	165.1 x 88.9	500	140	
6½ O.D x 4	165.1 x 114.3	500	140	
6½ O.D x 5½ O.D.	165.1 x 139.7	500	140	
8 x 4	219.1 x 114.3	500	215	

• SHIELD reserves the right to change the contents without notice.  
• Refer to UL/FM certificates for more information.

# Shield Threaded Outlet Mechanical Tee

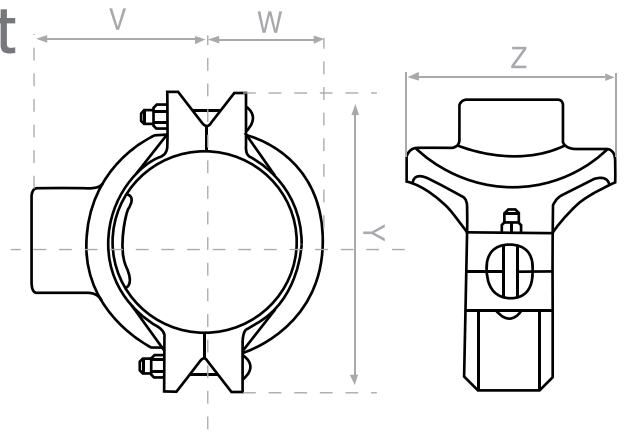

## SDG-42

Nominal Size Run x Branch Inch	Pipe O.D. mm	Maximum Working Pressure Psi	Hole Dia mm +1.6	Dimensions				Bolt Size in x mm
				Y mm	Z mm	V mm	W mm	
4 x 3 O.D.	114.3 x 76.1	300	70	178	103.5	98	67.5	1/2 x 75
4 x 3	114.3 x 88.9	300	89	178	124.0	98	67.5	1/2 x 75
5 1/2 O.D. x 1	139.7 x 33.4	300	38	210	77.0	100	82.0	5/8 x 85
5 1/2 O.D. x 1 1/4	139.7 x 42.4	300	51	210	91.0	105	82.0	5/8 x 85
5 1/2 O.D. x 1 1/2	139.7 x 48.3	300	51	210	91.0	105	82.0	5/8 x 85
5 1/2 O.D. x 2	139.7 x 60.3	300	64	210	110.0	108	82.0	5/8 x 85
5 1/2 O.D. x 3 O.D.	139.7 x 76.1	300	70	210	110.0	115	82.0	5/8 x 85
5 1/2 O.D. x 3	139.7 x 88.9	300	89	210	130.0	115	82.0	5/8 x 85
5 1/2 O.D. x 4	139.7 x 114.3	300	114	210	153.0	118	82.0	5/8 x 85
5 x 1 1/4	141.3 x 42.4	300	51	210	91.0	105	82.0	5/8 x 85
6 1/2 O.D. x 1/2	165.1 x 21.3	300	38	235	77.0	115	94.5	5/8 x 105
6 1/2 O.D. x 3/4	165.1 x 26.9	300	38	235	77.0	115	94.5	5/8 x 105
6 1/2 O.D. x 1	165.1 x 33.4	300	38	235	77.0	115	94.5	5/8 x 105
6 1/2 O.D. x 1 1/4	165.1 x 42.4	300	51	235	92.5	115	94.5	5/8 x 105
6 1/2 O.D. x 1 1/2	165.1 x 48.3	300	51	235	92.5	115	94.5	5/8 x 105
6 1/2 O.D. x 2	165.1 x 60.3	300	64	235	110.0	120	94.5	5/8 x 105
6 1/2 O.D. x 3 O.D.	165.1 x 76.1	300	70	235	110.0	125	94.5	5/8 x 105
6 1/2 O.D. x 3	165.1 x 88.9	300	89	235	130.0	125	94.5	5/8 x 105
6 1/2 O.D. x 4	165.1 x 114.3	225	114	240	155.0	130	94.5	5/8 x 105
6 x 1 1/4	168.3 x 42.4	300	51	240	92.5	115	96.5	5/8 x 105
6 x 1 1/2	168.3 x 48.3	300	51	240	92.5	115	96.5	5/8 x 105
6 x 2	168.3 x 60.3	300	64	240	110.0	121	96.5	5/8 x 105
6 x 2 1/2	168.3 x 73.0	300	70	240	110.0	127	96.5	5/8 x 105
6 x 3 O.D.	168.3 x 76.1	300	70	240	110.0	127	96.5	5/8 x 105
6 x 3	168.3 x 88.9	300	89	240	130.0	127	96.5	5/8 x 105
6 x 4	168.3 x 114.3	300	114	240	155.0	130	96.5	5/8 x 105
8 x 1	219.1 x 33.4	300	38	300	78.0	140	123.0	3/4 x 115
8 x 1 1/4	219.1 x 42.4	300	51	300	96.5	140	123.0	3/4 x 115
8 x 1 1/2	219.1 x 48.3	300	51	300	96.5	143	123.0	3/4 x 115
8 x 2	219.1 x 60.3	300	64	300	117.0	149	123.0	3/4 x 115
8 x 2 1/2	219.1 x 73.0	300	70	300	117.0	155	123.0	3/4 x 115
8 x 3 O.D.	219.1 x 76.1	300	70	300	117.0	155	123.0	3/4 x 115
8 x 3	219.1 x 88.9	300	89	300	133.5	155	123.0	3/4 x 115
8 x 4	219.1 x 114.3	300	114	300	164.0	160	123.0	3/4 x 115

Shield Mechanical Tees allow a direct branch connection to be made on a pipe run where sufficient space allows a hole to be cut. Material: Ductile Iron ASTM A536. Gasket Standard EPDM. Threads are available to BSPT or NPT and can be supplied in red coating or hot dipped galvanized.

• SHIELD reserves the right to change the contents without notice.  
• Refer to UL/FM certificates for more information.

The mechanical tee and cross features a gap between the bolt pads. Do not attempt to bring bolt pads together which would result in metal to metal when tightening bolts and nuts. Note that excessive torque may cause joint failure - the following table provides recommended bolt fastening torque.

Bolt Size Inch	Recommended Bolt Torque n-m
3/8	40 ~ 60
1/2	110 ~ 135
5/8	135 ~ 175
3/4	175 ~ 245
7/8	245 ~ 325





# Shield Grooved Outlet Mechanical Tee

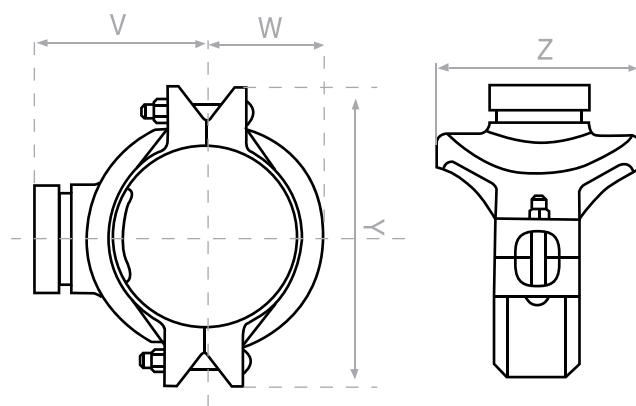

## SDG-44

Nominal Size Run x Branch Inch	Pipe O.D. mm	Maximum Working Pressure Psi	Hole Dia mm +1.6	Dimensions				Bolt Size in x mm
				Y mm	Z mm	V mm	W mm	
2½ x 1¼	73.0 x 42.2	300	51	144	84.5	75	49	½ x 60
3 x 2	88.9 x 60.3	300	64	160	104	92	53.5	½ x 75
4 x 2	114.3 x 60.3	300	64	186	104.4	101.5	68	½ x 75
4 x 2½	114.3 x 73.0	300	70	186	104.4	101.5	68	½ x 75
4 x 3 O.D	114.3 x 76.1	300	70	186	104.4	101.5	68	½ x 75
4 x 3	114.3 x 88.9	300	89	186	124	101.5	68	½ x 75
5½ O.D x 2	139.7 x 60.3	300	70	226	114	119	81	⅝ x 85
5½ O.D x 3 O.D	139.7 x 76.1	300	70	226	114	119	81	⅝ x 85
5½ O.D x 3	139.7 x 88.9	300	89	226	136	122	81	⅝ x 85
6½ O.D x 2	165.1 x 60.3	300	64	242	112	127.5	95	⅝ x 110
6½ OD x 3 O.D	165.1 x 76.1	300	70	242	112	127.5	95	⅝ x 110
6½ O.D x 3	165.1 x 88.9	300	89	242	142.6	141	95	⅝ x 110
6½ O.D x 4	165.1 x 114.3	300	114	242	157	141	95	⅝ x 110
6 x 2	168.3 x 60.3	300	64	246	114	134	98.5	⅝ x 110
6 x 4	168.3 x 114.3	300	114	246	157	142	98.5	⅝ x 110
8 x 2	219.1 x 60.3	300	70	320	118	158	123	¾ x 115
8 x 3 O.D	219.1 x 76.1	300	70	320	118	158	123	¾ x 115
8 x 3	219.1 x 88.9	300	89	320	142	161	123	¾ x 115
8 x 4	219.1 x 114.3	300	114	320	170	162	123	¾ x 115

• SHIELD reserves the right to change the contents without notice.  
• Refer to UL/FM certificates for more information.



# Shield Threaded Mechanical Cross

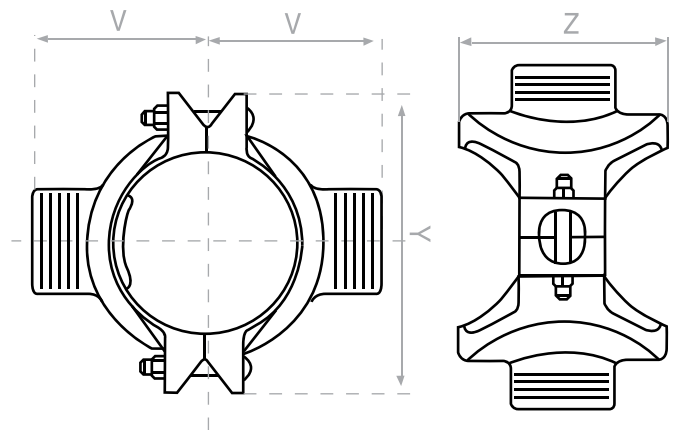

## SDG-47

Nominal Size Run x Branch Inch	Pipe O.D. mm	Maximum Working Pressure Psi	Hole Dia mm +1.6	Dimensions			Bolt Size in x mm
				Y mm	Z mm	V mm	
3 x 1/2	88.9 x 21.3	300	38	150.0	71.0	78.0	1/2 x 75
3 x 3/4	88.9 x 26.9	300	38	150.0	71.0	78.0	1/2 x 75
3 x 1	88.9 x 33.7	300	38	150.0	71.0	71.0	1/2 x 75
3 x 1 1/4	88.9 x 42.2	300	51	150.0	84.5	74.0	1/2 x 75
3 x 1 1/2	88.9 x 48.3	300	51	150.0	84.5	74.0	1/2 x 75
4 x 1/2	114.3 x 21.3	300	38	178.0	77.5	82.0	1/2 x 75
4 x 3/4	114.3 x 26.9	300	38	178.0	77.5	82.0	1/2 x 75
4 x 1	114.3 x 33.7	300	38	178.0	77.5	82.0	1/2 x 75
4 x 1 1/4	114.3 x 42.2	300	51	178.0	88.0	89.5	1/2 x 75
4 x 1 1/2	114.3 x 48.3	300	51	178.0	88.0	89.5	1/2 x 75
4 x 2	114.3 x 60.3	300	64	178.0	103.5	92.0	1/2 x 75
5 1/2 O.D. x 1	139.7 x 33.7	300	38	210.0	77.0	100.0	5/8 x 85
5 1/2 O.D. x 1 1/4	139.7 x 42.4	300	51	210.0	91.0	105.0	5/8 x 85
5 1/2 O.D. x 1 1/2	139.7 x 48.3	300	51	210.0	91.0	105.0	5/8 x 85
5 1/2 O.D. x 2	139.7 x 60.3	300	64	210.0	110.0	108.0	5/8 x 85
5 1/2 O.D. x 3 O.D.	139.7 x 76.1	300	70	210.0	110.0	115.0	5/8 x 85

• SHIELD reserves the right to change the contents without notice.  
• Refer to UL/FM certificates for more information.



# Shield Grooved Mechanical Cross

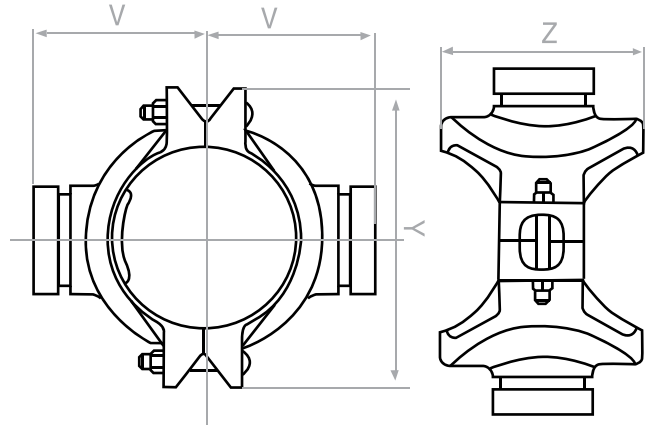

## SDG-49

Nominal Size Run x Branch Inch	Pipe O.D. mm	Maximum Working Pressure PSI	Hole Dia mm +1.6	Dimensions			Bolt Size  in x mm
				Y mm	Z mm	V mm	
2½ x 1¼	73.0 x 42.2	300	51	144.0	84.5	75.0	½ x 60
3 x 2	88.9 x 60.3	300	64	160.0	104.0	92.0	½ x 75
4 x 2	114.3 x 60.3	300	64	186.0	104.4	101.5	½ x 75
4 x 2½	114.3 x 73.0	300	70	186.0	104.4	101.5	½ x 75
4 x 3 O.D	114.3 x 76.1	300	70	186.0	104.4	101.5	½ x 75
4 x 3	114.3 x 88.9	300	89	186.0	124.0	101.5	½ x 75
5½ O.D x 2	139.7 x 60.3	300	70	226.0	114.0	119.0	⅝ x 85
5½ O.D x 3 O.D	139.7 x 76.1	300	70	226.0	114.0	119.0	⅝ x 85
5½ O.D x 3	139.7 x 88.9	300	89	226.0	136.0	122.0	⅝ x 85
6½ O.D x 2	165.1 x 60.3	300	64	242.0	112.0	127.5	⅝ x 110
6½ O.D x 3 O.D	165.1 x 76.1	300	70	242.0	112.0	127.5	⅝ x 110
6½ O.D x 3	165.1 x 88.9	300	89	242.0	142.6	141.0	⅝ x 110
6½ O.D x 4	165.1 x 114.3	300	114	242.0	157.0	141.0	⅝ x 110
6 x 2	168.3 x 60.3	300	64	246.0	114.0	134.0	⅝ x 110
6 x 4	168.3 x 114.3	300	114	246.0	157.0	142.0	⅝ x 110
8 x 2	219.1 x 60.3	300	70	320.0	118.0	158.0	¾ x 115
8 x 3 O.D	219.1 x 76.1	300	70	320.0	118.0	158.0	¾ x 115
8 x 3	219.1 x 88.9	300	89	320.0	142.0	161.0	¾ x 115
8 x 4	219.1 x 114.3	300	114	320.0	170.0	162.0	¾ x 115

• SHIELD reserves the right to change the contents without notice.  
• Refer to UL/FM certificates for more information.



# Shield U-Bolt Mechanical Tee

## SDG-40

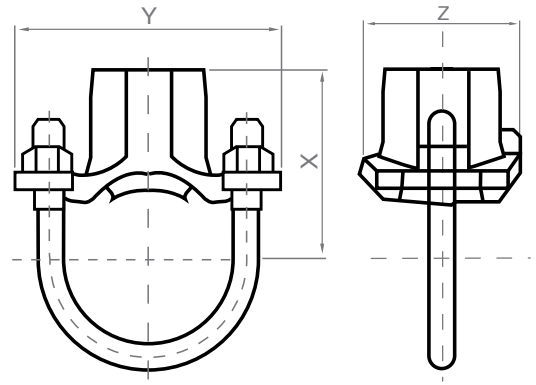

Nominal Size Inch	Hole Dia mm +1.6	Maximum Working Pressure PSI	Dimensions			U-Bolt Size in x mm
			X mm	Y mm	Z mm	
1¼ x ½	30	300	53.0	89.0	56.0	¾ x 60
1¼ x ¾	30	300	53.0	89.0	56.0	¾ x 60
1¼ x 1	30	300	56.0	89.0	56.0	¾ x 60
1½ x ½	30	300	55.0	89.0	56.0	¾ x 67
1½ x ¾	30	300	55.0	89.0	56.0	¾ x 67
1½ x 1	30	300	58.0	89.0	56.0	¾ x 67
2 x ½	30	300	64.0	98.0	56.0	¾ x 82
2 x ¾	30	300	64.0	98.0	56.0	¾ x 82
2 x 1	30	300	67.0	98.0	56.0	¾ x 82
2½ x ½	30	300	69.0	111.0	56.0	¾ x 95
2½ x ¾	30	300	69.0	111.0	56.0	¾ x 95
2½ x 1	30	300	72.0	111.0	56.0	¾ x 95

# Shield Groove Specifications

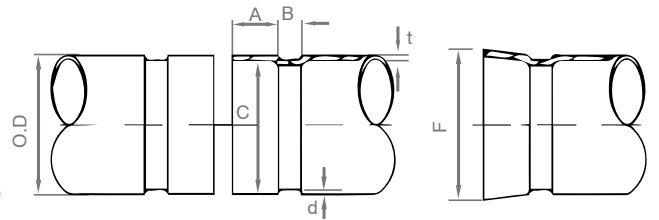

Nominal Size Inch	Pipe Outside Diameter			Gasket Seat 'A' (+/-)0.030	Groove Diameter 'C'		Groove Width 'B'		Groove Depth 'D'	Minimum Pipe Wall Thickness 'T'		Max 'F' Flare Dia.
	Actual	Tolerance			Maximum	Tolerance (+)0.000	Roll Groove (+/-)0.030	Cut Groove (+/-)0.031		Roll Groove	Cut Groove	
		(+)	(-)									
1¼	1.660	0.016	0.016	0.625	1.535	-0.015	0.281	0.312	0.063	0.065	0.140	1.77
1½	1.900	0.019	0.019	0.625	1.775	-0.015	0.281	0.312	0.063	0.065	0.140	2.01
2	2.375	0.024	0.024	0.625	2.250	-0.015	0.344	0.312	0.063	0.065	0.154	2.48
2½	2.875	0.029	0.029	0.625	2.720	-0.018	0.344	0.312	0.078	0.083	0.187	2.98
3 O.D	3.000	0.030	0.030	0.625	2.845	-0.018	0.344	0.312	0.078	0.083	0.188	3.10
3	3.500	0.035	0.031	0.625	3.344	-0.018	0.344	0.312	0.078	0.083	0.188	3.60
4	4.500	0.045	0.031	0.625	4.334	-0.020	0.344	0.312	0.083	0.083	0.203	4.60
5½ O.D	5.500	0.056	0.031	0.625	5.334	-0.020	0.344	0.375	0.083	0.109	0.203	5.60
5	5.563	0.056	0.031	0.625	5.395	-0.022	0.344	0.375	0.084	0.109	0.203	5.66
6	6.625	0.063	0.031	0.625	6.445	-0.022	0.344	0.375	0.085	0.109	0.219	6.73
8	8.625	0.063	0.031	0.750	8.441	-0.025	0.469	0.375	0.092	0.109	0.238	8.80
10	10.750	0.063	0.031	0.750	10.562	-0.027	0.469	0.500	0.094	0.134	0.250	10.92
12	12.750	0.063	0.031	0.750	12.531	-0.030	0.469	0.500	0.109	0.156	0.279	12.92
14	14.000	0.063	0.031	0.750	13.781	-0.030	0.469	0.500	0.109	0.156	0.281	14.10
16	16.000	0.063	0.031	0.750	15.781	-0.030	0.469	0.500	0.109	0.165	0.312	16.10
18	18.000	0.060	0.030	1.000	17.781	-0.025	0.469	0.500	0.109	0.165	0.312	18.16
20	20.000	0.060	0.030	1.000	19.781	-0.025	0.469	0.500	0.109	0.188	0.312	20.16

• SHIELD reserves the right to change the contents without notice.  
• Refer to UL/FM certificates for more information.







# Pipe Support & Hangers

For Water, HVAC & Fire Fighting Applications

# Shield Swivel Ring Hanger

## Function

Designed for the suspension of non-insulated stationary pipe lines. The insert nut allows a vertical adjustment after installation, is tapped to NFPA reduced rod size standards. SD-HBF has a layer of felt which separates the pipe from the hanger to reduce vibration and sound.

## Approval

Federal Specification WW-H-171E & A-A-1192 (Type 10)  
Manufacturers Standardization Society MSS SP-69 & SP-58 (Type 10)  
UL Listed/FM Approved.

## Material and Finish

Pre-Galvanized coil adheres to ASTM A653 G90 or  
Low Carbon Steel - Electro Galvanized to ASTM B633 or  
Low Carbon Steel - Hot dipped galvanized to ASTM A123

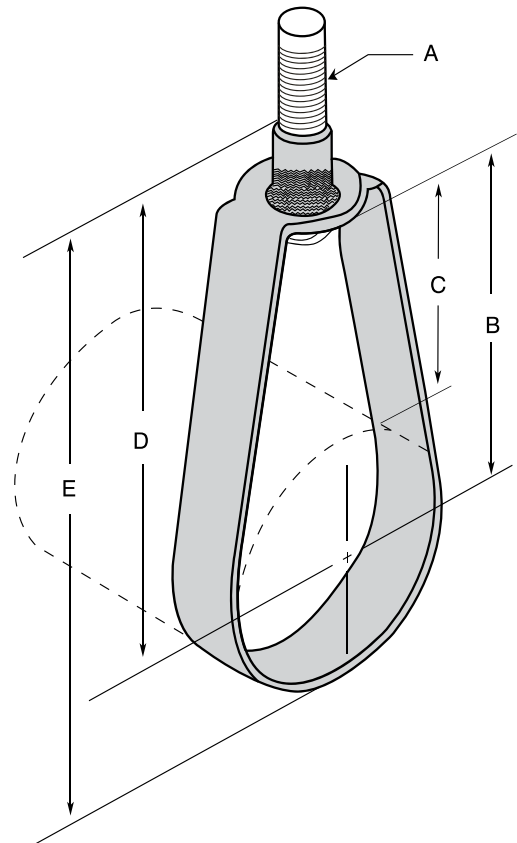

## SD-HB

Pipe Size Inch	Rod Size A Inch	Dimensions				Max. Rec. Load lbs.
		B Inch	C Inch	D Inch	E Inch	
1/2	3/8	1 1/8	1 7/16	2 3/4	3 1/16	300
3/4	3/8	1 11/16	1 1/8	2 1/2	3 1/16	300
1	3/8	1 5/8	1	2 1/2	3 3/16	300
1 1/4	3/8	1 15/16	1 1/16	2 13/16	3 9/16	300
1 1/2	3/8	2 1/8	1 1/16	3 1/8	3 7/8	300
2	3/8	2 7/16	1 1/8	3 5/16	4 3/8	300
2 1/2	3/8	2 3/4	1 1/4	3 11/16	5	525
3	3/8	2 7/8	1 1/8	3 3/4	5 9/16	525
3 1/2	3/8	3 3/8	1 3/8	4 5/16	6 5/16	525
4	3/8	3 7/8	1 1/2	4 1/2	7	650
5	1/2	4 5/8	1 5/8	5 5/8	8 3/8	1000
6	1/2	5 5/8	2 1/4	6 1/2	9 13/16	1000
8	1/2	6 13/16	2 7/16	7 15/16	12 1/4	1000

Note: a) Swivel Nut is coming along with hanger.  
b) Swivel Nut is available for 10mm and 12mm Rod size.  
c) Refer to UL/FM certificates for more information.  
d) Swivel hanger is also available in SS material upon request.  
e) SHIELD reserves the right to change the contents without notice.

# Shield Clevis Hanger

## Function

Designed for the suspension of non-insulated stationary pipe lines. SD-HCF has a layer of felt which separates the pipe from the hanger to reduce vibration and sound.

## Approval

Federal Specification WW-H-171E & A-A-1192A (Type 1)  
Manufacturers Standardization Society MSS SP-69 & SP-58 (Type 1)  
UL Listed/FM Approved.

## Material and Finish

Pre-Galvanized coil (upto 4") adheres to ASTM A653 G90 or  
Low Carbon Steel - Electro Galvanized to ASTM B633 or  
Low Carbon Steel - Hot dipped galvanized to ASTM A123

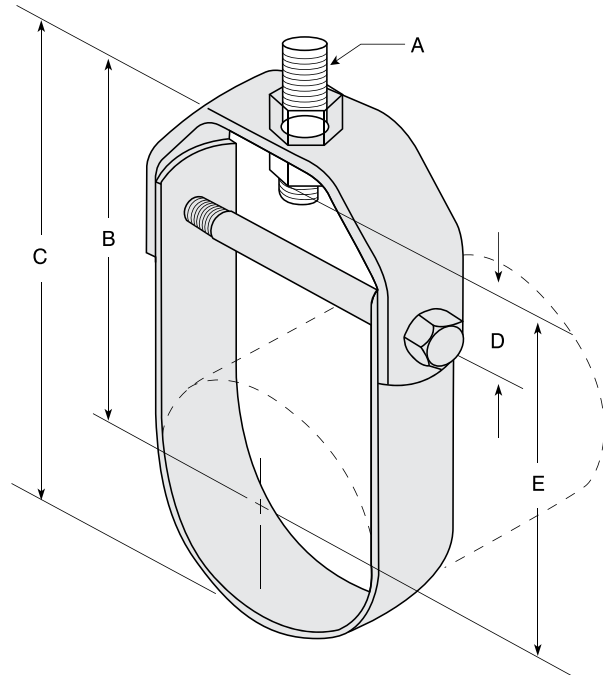

## SD-HC

Pipe Size Inch	Rod Size A Inch	Adjustment				Cross Bolt Inch	Max. Rec. Load lbs.
		B Inch	C Inch	D Inch	E Inch		
1/2	3/8	27/16	27/8	15/8	2	1/4	610
3/4	3/8	25/8	31/8	11/4	23/16	1/4	610
1	3/8	31/16	33/4	15/8	25/8	1/4	610
1 1/4	3/8	33/8	43/16	15/8	215/16	1/4	610
1 1/2	3/8	31/2	47/16	1 1/2	31/16	1/4	610
2	3/8	33/4	5	15/8	35/16	1/4	610
2 1/2	1/2	37/8	53/8	1 1/8	31/4	3/8	1130
3	1/2	41/4	6	1 1/8	35/8	3/8	1130
3 1/2	1/2	41/2	6 1/2	1 1/4	37/8	3/8	1130
4	5/8	5 1/2	7 11/16	1 3/4	4 11/16	3/8	1430
5	5/8	6 1/8	9 1/8	1 7/8	5 5/16	1/2	1430
6	3/4	6 7/8	10 1/8	1 5/8	6	1/2	1940
8	7/8	8 3/4	12 7/8	2 1/8	7 7/8	5/8	2000
10	7/8	9 1/4	14 5/8	1 3/4	8 1/8	3/4	3600
12	7/8	11 5/8	18	2 1/2	10 1/2	3/4	3800
14	1	12 3/4	19 3/4	2 5/8	11 1/4	7/8	4200
16	1	14 1/8	22 1/8	2 5/8	13 5/8	1	4600
18	1 1/8	16 1/2	25 1/2	3 1/2	15	1 1/8	4800
20	1 1/4	18	28	4 1/8	16 1/8	1 1/4	4800
24	1 1/4	20 1/4	32 1/4	4 3/4	18 3/8	1 1/4	4800
30	1 1/4	24 1/2	38 7/8	5 1/2	21 1/2	1 1/4	6000
36	1 1/2	32	50	8 3/4	30	1 1/2	9500

- Note:  
a) Use of an upper locknut ensures proper performance. Pipe spacers provided on 30" and larger clevises. If ordering SD-HCF felt lined hangers for pipe size of 3 1/2" or under, order the next largest size to allow for the thickness of the felt lining.  
b) "D" Adjustment (Top of cross bolt to bottom of hanger rod nut)  
c) When an over-sized clevis is used, a pipe spacer should be placed over the clevis bolt to prevent the lower U-strap from moving inward.  
d) Clevis hanger is also available in SS material upon request.  
e) Refer to UL/FM certificates for more information.  
f) SHIELD reserves the right to change the contents without notice.



# Shield Pipe Clamp with Lining



## Features

- Designed for Horizontal, vertical and suspended installations.
- Suitable for Steel, copper and PVC pipes.
- Welded Nut M8/M10 with option of M10/M12.
- Connection thread with M8/M10 dual-tapped boss.
- Side Screw: 6 x 20 – Phillip head with vicer.
- High rigidity due to reinforcing rib.
- With highly elastic vibration control lining, vibration control tested.

## Approval

Manufacturers Standardization Society ANSI/MSS SP-69 & SP-58 (Type 12)  
Federal Specification WW-H-171E & A-A-1192A (Type 25)

## Material

Mild Steel & EPDM Rubber

## Finishing

Electro galvanized as per ASTM B633 Standards

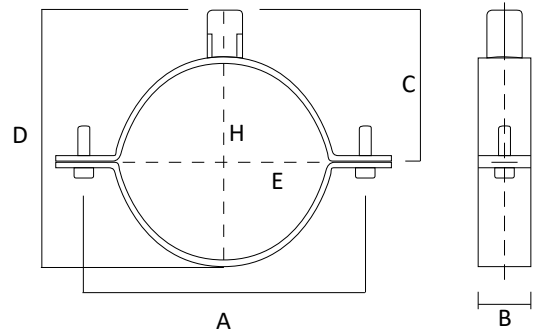

## SD-GE-RLC

Size	Pipe O.D.	Dimensions						Max. Load
		H	E	A	B	C	D	
Inch	mm	mm	mm	mm	mm	mm	mm	Kg
3/8	17.1	15	19	59	20	23	30	450
1/2	21.3	20	25	66	20	26	37	450
3/4	26.7	26	30	72	20	29	43	450
1	33.4	32	36	79	20	33	50	450
1 1/4	42.2	38	43	86	20	36	57	450
1 1/2	48.3	47	51	92	20	39	63	450
1 1/2-54	54.0	53	58	98	20	42	69	450
2	60.3	60	64	104	20	45	75	450
2-63	63.0	63	66	108	20	47	72	450
2-70	70.0	68	72	114	20	50	85	450
2 1/2	73.0	74	80	119	20	53	90	600
2 1/2-83	83.0	81	86	127	20	57	98	600
3	88.9	87	92	134	20	60	105	600
3 1/2	101.6	99	105	144	20	65	115	600
3 1/2-110	110.0	107	112	164	20	70	125	600
4	114.3	113	118	159	20	73	130	600
4-125	125.0	125	130	169	20	78	140	600
4-133	133.0	131	137	177	20	82	148	600
5	141.3	138	142	184	20	85	155	600
5-150	150.0	148	153	194	20	90	165	600
5-160	160.0	159	166	204	25	95	175	600
6	168.3	168	172	212	25	99	183	600
6-210	210.0	200	212	244	25	115	215	950
8	219.1	215	220	264	25	125	235	950
10	273.0	269	274	294	25	140	265	950
12	323.8	313	318	367	25	177	339	1200

- Note:
- Measurements are subject to 5% tolerance.
  - Other Sizes available on request.
  - Hot Dipped Galvanized can be supplied upon request.
  - Refer to UL certificate for more information.
  - SHIELD reserves the right to change the contents without notice.

# Shield Pipe Clamp with Lining



## SD-GE-RLC

### Selection of Lined Pipe Hangers for Different Types of Pipes

Size Inch	Copper mm	Steel (SCH 40)		UPVC / PE mm	ABS
		Inch	mm		
3/8"	15, 18	-	16	-	-
1/2	22	1/2	22	20	DN15 (21.4)
3/4	24, 28	3/4	28	25	DN20 (26.8)
1	35	1	35	32, 38	DN25 (33.6)
1 1/4	42	1 1/4	42	40, 43	DN32 (42.3)
1 1/2	-	1 1/2	48	45	DN40 (48.3)
1 1/2-54	54	-	-	54	-
2	64	2	60	60	DN50 (60.4)
2-63	-	-	-	-	-
2-70	67, 70	-	-	70	-
2 1/2	76	2 1/2	75	75	DN65 (75.4)
2 1/2-83	80	-	-	83	-
3	-	3	90	90	-
3 1/2	102, 105	-	-	102	DN80 (88.9)
3 1/2-110	108	-	-	110	-
4	-	4	115	115	DN100 (114.3)
4-125	125	-	-	125	-
4-133	-	-	-	135	-
5	-	5	140	140	DN125 (127.0)
5-150	-	-	-	152	-
5-160	159	-	-	160	-
6	167	6	168	-	DN150 (152.4)
6-210	206	-	-	200	-
8	-	8	219	220, 225	DN200 (203.2)
10	-	-	-	250	DN225 (228.6)
12	-	-	-	-	DN300 (304.8)

Note:

- a) Measurements are subject to 5% tolerance.
- b) Refer to UL certificate for more information.
- b) SHIELD reserves the right to change the contents without notice.

# Shield Pipe Clamp



## Features

- Designed for Horizontal, vertical and suspended installations.
- Welded Nut M8/M10 with option of M10/M12.
- High - Strength round welded connecting nuts.
- The two locking screws allow adjustment.
- Can be used as a pipe anchor point.
- Suitable for installations without vibration control requirements.

## Approval

Manufacturers Standardization Society ANSI/MSS SP-69 & SP-58 (Type 12)  
Federal Specification WW-H-171E & A-A-1192A (Type 25)

## Material

Mild Steel

## Finishing

Electro galvanized as per ASTM B633 Standards

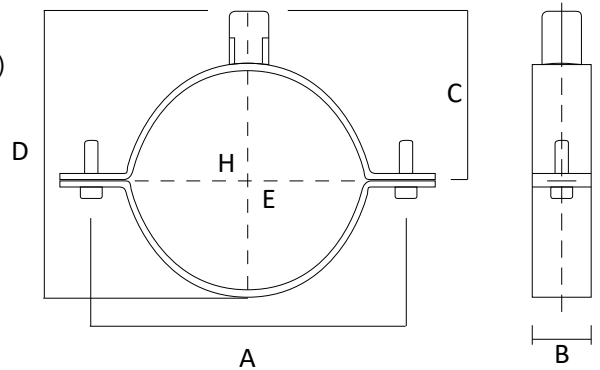

## SD-GE-PPC

Size	Pipe O.D.	Dimensions						Max. Load
		H	E	A	B	C	D	
Inch	mm	mm	mm	mm	mm	mm	mm	Kg
3/8"	17.1	15	19	59	20	23	30	450
1/2	21.3	20	25	66	20	26	37	450
3/4	26.7	26	30	72	20	29	43	450
1	33.4	32	36	79	20	33	50	450
1 1/4	42.2	38	43	86	20	36	57	450
1 1/2	48.3	47	51	92	20	39	63	450
1 1/2-54	54.0	53	58	98	20	42	69	450
2	60.3	60	64	104	20	45	75	450
2-63	63.0	63	66	108	20	47	72	450
2-70	70.0	68	72	114	20	50	85	450
2 1/2	73.0	74	80	119	20	53	90	600
2 1/2-83	83.0	81	86	127	20	57	98	600
3	88.9	87	92	134	20	60	105	600
3 1/2	101.6	99	105	144	20	65	115	600
3 1/2-110	110.0	107	112	164	20	70	125	600
4	114.3	113	118	159	20	73	130	600
4-125	125.0	125	130	169	20	78	140	600
4-133	133.0	131	137	177	20	82	148	600
5	141.3	138	142	184	20	85	155	600
5-150	150.0	148	153	194	20	90	165	600
5-160	160.0	159	166	204	25	95	175	600
6	168.3	168	172	212	25	99	183	600
6-210	210.0	200	212	244	25	115	215	950
8	219.1	215	220	264	25	125	235	950
10	273.0	269	274	294	25	140	265	950
12	323.8	313	318	367	25	177	339	1200

### Note:

- Measurements are subject to 5% tolerance.
- Other Sizes available on request.
- Hot Dipped Galvanized can be supplied upon request.
- Refer to UL certificate for more information.
- SHIELD reserves the right to change the contents without notice.

# Shield U Strap Hanger with Lining

## Features

- Designed for mount plain or insulated pipes.
- It can be used as a pipe anchor with Rubber Support Insert also.
- Vibration and Sound Control tested & verified with highly elastic lining.

## Approval

Manufacturers Standardization Society ANSI/MSS SP-69 & SP-58  
Federal Specification WW-H-171E & A-A-1192A

## Material

Mild Steel & EPDM Rubber

## Finishing

Electro galvanized as per ASTM B633 Standards

## SD-GE-RUS

Size	Pipe O.D.	Dimensions			Bolt Size	Max. Load
		A	B	Width		
Inch	mm	mm	mm	mm	mm	Kg
1/2	21.3	76	51	20	M8	500
3/4	26.7	82	57	20	M8	500
1	33.4	89	64	20	M8	500
1 1/4	42.2	96	71	20	M8	500
1 1/2	48.3	102	77	20	M8	500
-	54.0	108	83	20	M8	500
2	60.3	114	89	20	M8	500
-	67.0	121	96	25	M8	500
2 1/2	73.0	145	113	25	M8	600
-	82.0	152	120	25	M8	600
3	88.9	160	128	25	M8	600
3 1/2	101.6	170	138	25	M8	600
-	110.0	178	146	25	M8	600
4	114.3	185	153	25	M8	600
-	126.0	196	164	30	M8	600
5	141.3	210	178	30	M10	600
-	148.0	218	186	30	M10	600
-	155.0	225	193	30	M10	600
6	168.3	237	205	30	M10	600
-	179.0	249	217	30	M10	600
-	190.0	260	228	30	M10	800
-	205.0	275	243	30	M10	800
8	219.1	289	257	30	M10	800
-	230.0	300	268	30	M10	800
-	241.0	332	291	30	M12	1250
-	263.0	354	313	30	M12	1250
10	273.0	364	323	30	M18	1250
-	295.0	386	345	40	M18	1250

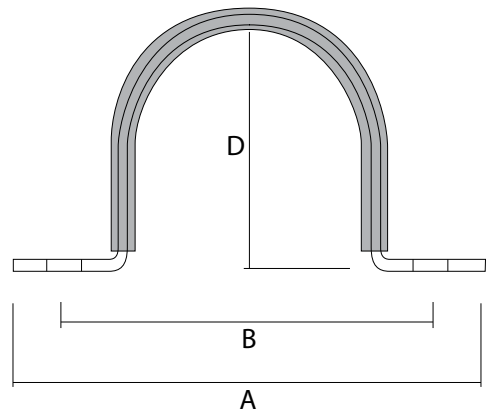

Note:

- Measurements are subject to 5% tolerance.
- Other Sizes available on request.
- Hot Dipped Galvanized can be supplied upon request.
- SHIELD reserves the right to change the contents without notice.

# Shield U Strap Hanger

## Features

- Designed for mount plain or insulated pipes.
- U Strap Hangers can be used as a pipe anchor with rubber support inserts also.

## Approval

Manufacturers Standardization Society ANSI/MSS SP-69 & SP-58 (Type 26)  
Federal Specification WW-H-171E & A-A-1192A (Type 26)

## Material

Mild Steel

## Finishing

Electro galvanized as per ASTM B633 Standards

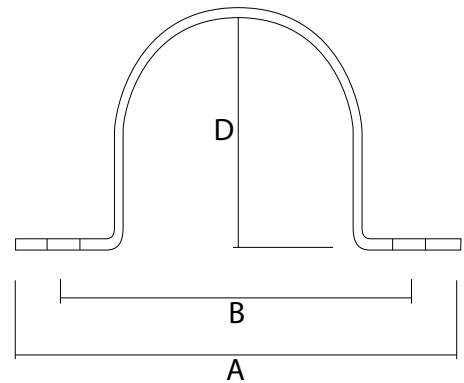

## SD-GE-US

Size	Pipe O.D.	Dimensions			Bolt Size	Max. Load
		A	B	Width		
Inch	mm	mm	mm	mm	mm	Kg
1/2	21.3	76	51	20	M8	500
3/4	26.7	82	57	20	M8	500
1	33.4	89	64	20	M8	500
1 1/4	42.2	96	71	20	M8	500
1 1/2	48.3	102	77	20	M8	500
-	54.0	108	83	20	M8	500
2	60.3	114	89	20	M8	500
-	67.0	121	96	25	M8	500
2 1/2	73.0	145	113	25	M8	600
-	82.0	152	120	25	M8	600
3	88.9	160	128	25	M8	600
3 1/2	101.6	170	138	25	M8	600
-	110.0	178	146	25	M8	600
4	114.3	185	153	25	M8	600
-	126.0	196	164	30	M8	600
5	141.3	210	178	30	M10	600
-	148.0	218	186	30	M10	600
-	155.0	225	193	30	M10	600
6	168.3	237	205	30	M10	600
-	179.0	249	217	30	M10	600
-	190.0	260	228	30	M10	800
-	205.0	275	243	30	M10	800
8	219.1	289	257	30	M10	800
-	230.0	300	268	30	M10	800
-	241.0	332	291	30	M12	1250
-	263.0	354	313	30	M12	1250
10	273.0	364	323	30	M18	1250
-	295.0	386	345	40	M18	1250

Note:

- Measurements are subject to 5% tolerance.
- Other Sizes available on request.
- Hot Dipped Galvanized can be supplied upon request.
- SHIELD reserves the right to change the contents without notice.

# Shield Riser Hanger/Clamp with Lining

## Features

Designed to act as a rigid support / guide for vertical pipes to control the suspension in pipeline. Equally useable in most of the pipe types.

- Strengthened bolts for high load capacity.
- Highly elastic lining for sound and vibrations control.

## Approval

Manufacturers Standardization Society ANSI/MSS  
 SP-69 & SP-58 (Type 8)  
 Federal Specification WW-H-171E & A-A-1192A  
 (Type 8)

## Material

Mild Steel & EPDM Rubber

## Finishing

Electro galvanized as per ASTM B633 Standards

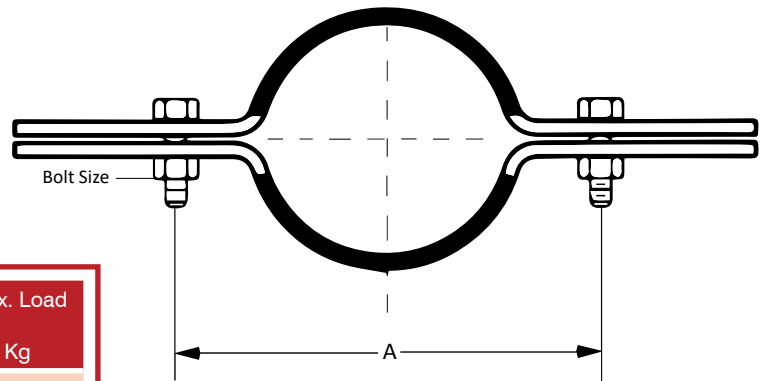

## SD-GE-RRC

Size	Pipe O.D.	A	Bolt Size	Max. Load
Inch	mm	mm	mm	Kg
1/2	21.3	57	M10	1250
3/4	26.7	68	M10	1250
1	33.4	76	M10	1250
1 1/4	42.2	90	M10	1250
1 1/2	48.3	110	M10	1250
2	60.3	130	M10	1850
2 1/2	73.0	142	M12	1850
3	88.9	161	M12	2250
4	114.3	190	M12	3600
6	168.3	258	M16	4500
8	219.1	333	M16	4500
10	273.0	409	M16	5800
12	323.8	467	M20	7300

### Note:

- Measurements are subject to 5% tolerance.
- Other Sizes available on request.
- Hot Dipped Galvanized can be supplied upon request.
- SHIELD reserves the right to change the contents without notice.



# Shield Riser Hanger/ Clamp

## Features

Designed to act as a rigid support for vertical pipes to control the suspension in pipeline. Equally useable in most of the pipe types.

Strengthened bolts for high load capacity.

## Approval

Manufacturers Standardization Society ANSI/MSS

SP-69 & SP-58 (Type 8)

Federal Specification WW-H-171E & A-A-1192A

(Type 8)

## Material

Mild Steel

## Finishing

Electro galvanized as per ASTM B633 Standards

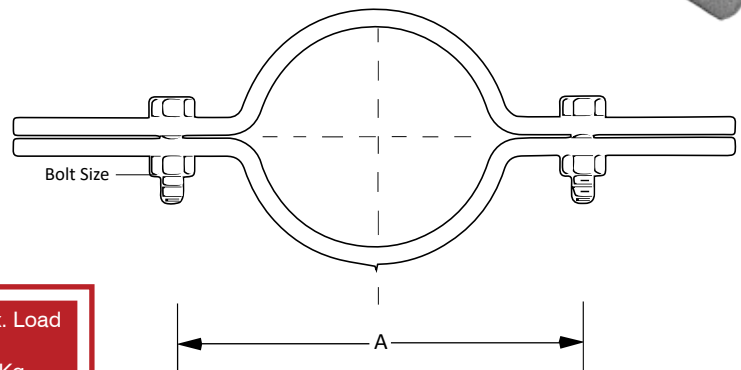

## SD-GE-PRC

Size	Pipe O.D.	A	Bolt Size	Max. Load
Inch	mm	mm	mm	Kg
1/2	21.3	57	M10	1250
3/4	26.7	68	M10	1250
1	33.4	76	M10	1250
1 1/4	42.2	90	M10	1250
1 1/2	48.3	110	M10	1250
2	60.3	130	M10	1850
2 1/2	73.0	142	M12	1850
3	88.9	161	M12	2250
4	114.3	190	M12	3600
6	168.3	258	M16	4500
8	219.1	333	M16	4500
10	273.0	409	M16	5800
12	323.8	467	M20	7300

### Note:

- Measurements are subject to 5% tolerance.
- Other Sizes available on request.
- Hot Dipped Galvanized can be supplied upon request.
- SHIELD reserves the right to change the contents without notice.

# Shield U Bolt

## Features

- Designed to use as a support, anchor or guide for various types of pipes.
- High load capacity due to one piece design.
- Supplied with two Nuts & Washers.
- Special U bolts with Longer Tangents and Threads can be furnished upon request.

## Approval

Manufacturers Standardization Society ANSI/MSS

SP-69 & SP-58 (Type 24)

Federal Specification WW-H-171E & A-A-1192A

(Type 24)(Type 8)

## Material

Mild Steel

## Finishing

Electro galvanized as per ASTM B633 Standards

## SD-UB

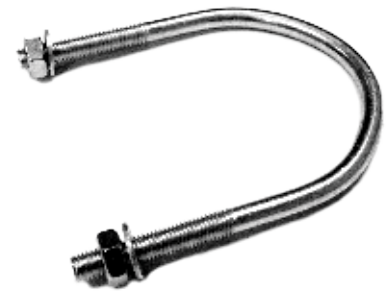
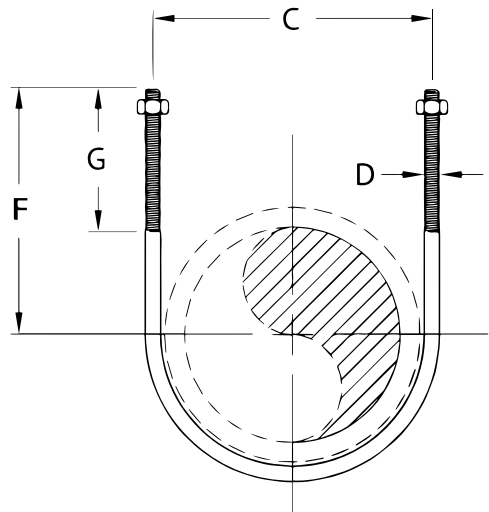

Size	Pipe O.D.	Dimensions			
		D	C	F	G
Inch	mm	mm	mm	mm	mm
1/2	21.3	M8	31	35	35
3/4	26.7	M10	39	40	38
1	33.4	M10	45	45	40
1 1/4	42.2	M10	54	55	45
1 1/2	48.3	M10	60	55	45
2	54.0	M10	72	60	45
2 1/2	60.3	M10	86	75	55
3	67.0	M10	102	80	55
4	73.0	M10	128	95	55
6	82.0	M12	184	130	70
8	88.9	M12	239	155	70
10	101.6	M20	273	370	100
12	110.0	M20	324	420	100
14	114.3	M20	356	455	100
16	126.0	M20	406	505	100
18	141.3	M24	457	555	100
20	148.0	M24	508	605	100
24	155.0	M24	610	710	100

### Note:

- Measurements are subject to 5% tolerance.
- Other Sizes available on request.
- U Bolt sizes can be modified to match with Rubber support inserts.
- Alternate rod sizes for different pipe sizes are also available.
- Hot Dipped Galvanized can be supplied upon request.
- Refer to UL certificate for more information.
- SHIELD reserves the right to change the contents without notice.

# Shield Rubber Support Insert



## Features

- Very high load bearing capacity.
- Dimensionally accurate as each piece is moulded.
- Tongue and Groove design for small sizes.
- Unique DOVETAIL lock for higher sizes.
- Excellent resistance to Deterioration / Distortion.
- Available with steel reinforcements for higher sizes.

## Material

EPDM Rubber

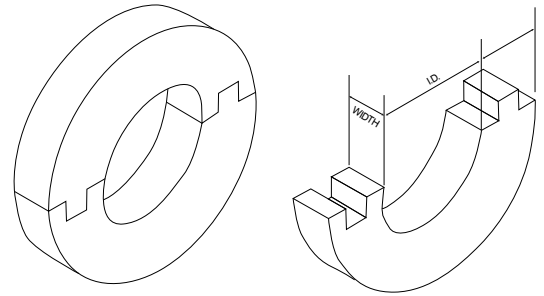

## SD-RSI

Nominal Pipe Size		SCH40 Steel Pipe O.D.	Width of Rubber Support Insert	Part numbers for Rubber Support Insert Thickness								
				1/2 (13) Inch (mm)	3/4 (19) Inch (mm)	1 (25) Inch (mm)	1 1/4 (32) Inch (mm)	1 1/2 (38) Inch (mm)	2 (50) Inch (mm)	2 1/2 (65) Inch (mm)	3 (75) Inch (mm)	
Inch	mm	mm	mm									
1/2	15	21.3	25	SD-RSI13-01	SD-RSI19-01	SD-RSI25-01	SD-RSI32-01	SD-RSI38-01	SD-RSI50-01	SD-RSI65-01	SD-RSI75-01	
3/4	20	26.7	25	SD-RSI13-02	SD-RSI19-02	SD-RSI25-02	SD-RSI32-02	SD-RSI38-02	SD-RSI50-02	SD-RSI65-02	SD-RSI75-02	
1	25	33.4	25	SD-RSI13-03	SD-RSI19-03	SD-RSI25-03	SD-RSI32-03	SD-RSI38-03	SD-RSI50-03	SD-RSI65-03	SD-RSI75-03	
1 1/4	32	42.2	25	SD-RSI13-04	SD-RSI19-04	SD-RSI25-04	SD-RSI32-04	SD-RSI38-04	SD-RSI50-04	SD-RSI65-04	SD-RSI75-04	
1 1/2	40	48.3	25	SD-RSI13-05	SD-RSI19-05	SD-RSI25-05	SD-RSI32-05	SD-RSI38-05	SD-RSI50-05	SD-RSI65-05	SD-RSI75-05	
2	50	60.3	25	SD-RSI13-06	SD-RSI19-06	SD-RSI25-06	SD-RSI32-06	SD-RSI38-06	SD-RSI50-06	SD-RSI65-06	SD-RSI75-06	
2 1/2	65	73.0	38	SD-RSI13-07	SD-RSI19-07	SD-RSI25-07	SD-RSI32-07	SD-RSI38-07	SD-RSI50-07	SD-RSI65-07	SD-RSI75-07	
3	80	88.9	38	SD-RSI13-08	SD-RSI19-08	SD-RSI25-08	SD-RSI32-08	SD-RSI38-08	SD-RSI50-08	SD-RSI65-08	SD-RSI75-08	
3 1/2	90	101.6	38	SD-RSI13-09	SD-RSI19-09	SD-RSI25-09	SD-RSI32-09	SD-RSI38-09	SD-RSI50-09	SD-RSI65-09	SD-RSI75-09	
4	100	114.3	38	SD-RSI13-10	SD-RSI19-10	SD-RSI25-10	SD-RSI32-10	SD-RSI38-10	SD-RSI50-10	SD-RSI65-10	SD-RSI75-10	
5	125	141.3	38	SD-RSI13-11	SD-RSI19-11	SD-RSI25-11	SD-RSI32-11	SD-RSI38-11	SD-RSI50-11	SD-RSI65-11	SD-RSI75-11	
6	150	168.3	50	SD-RSI13-12	SD-RSI19-12	SD-RSI25-12	SD-RSI32-12	SD-RSI38-12	SD-RSI50-12	SD-RSI65-12	SD-RSI75-12	
8	200	219.1	50	SD-RSI13-13	SD-RSI19-13	SD-RSI25-13	SD-RSI32-13	SD-RSI38-13	SD-RSI50-13	SD-RSI65-13	SD-RSI75-13	
10	250	273.0	50	SD-RSI13-14	SD-RSI19-14	SD-RSI25-14	SD-RSI32-14	SD-RSI38-14	SD-RSI50-14	SD-RSI65-14	SD-RSI75-14	
12	300	323.8	50	SD-RSI13-15	SD-RSI19-15	SD-RSI25-15	SD-RSI32-15	SD-RSI38-15	SD-RSI50-15	SD-RSI65-15	SD-RSI75-15	
14	350	355.6	50	SD-RSI13-16	SD-RSI19-16	SD-RSI25-16	SD-RSI32-16	SD-RSI38-16	SD-RSI50-16	SD-RSI65-16	SD-RSI75-16	
16	400	406.4	50	SD-RSI13-17	SD-RSI19-17	SD-RSI25-17	SD-RSI32-17	SD-RSI38-17	SD-RSI50-17	SD-RSI65-17	SD-RSI75-17	
18	450	457.2	50	SD-RSI13-18	SD-RSI19-18	SD-RSI25-18	SD-RSI32-18	SD-RSI38-18	SD-RSI50-18	SD-RSI65-18	SD-RSI75-18	
20	500	508.0	50	SD-RSI13-19	SD-RSI19-19	SD-RSI25-19	SD-RSI32-19	SD-RSI38-19	SD-RSI50-19	SD-RSI65-19	SD-RSI75-19	
24	600	610.0	50	SD-RSI13-20	SD-RSI19-20	SD-RSI25-20	SD-RSI32-20	SD-RSI38-20	SD-RSI50-20	SD-RSI65-20	SD-RSI75-20	

- Note:
- Measurements are subject to 5% tolerance.
  - Other Sizes available on request.
  - Hot Dipped Galvanized can be supplied upon request.
  - SHIELD reserves the right to change the contents without notice.

# Shield Threaded Rod

## Features

- Designed for use as a Double end Studs with a nut on either side or as studs.
- Right Handed.
- Coarse Threads.
- Commercial Nut Fit.

## Standard

DIN 975, steel - Property Class 4.8

## Material

Mild Steel

## Finishing

Zinc Plated

## SD-TR

Thread (D)	Coarse & Fine Thread Length (L) = 1000mm, 2000mm & 3000 mm										
	mm	M4	M5	M6	M7	M8	M8	M10	M10	M12	M12
Diameter	Inch	0.157	0.197	0.236	0.276	0.315	0.315	0.315	0.394	0.472	0.472
Pitch	mm	0.700	0.800	1.000	1.000	1.000	1.250	1.250	1.500	1.250	1.750
Thread (D)	mm	M14	M16	M16	M18	M20	M20	M22	M24	M27	M30
Diameter	Inch	0.551	0.630	0.630	0.709	0.787	0.787	0.866	0.945	1.063	1.181
2.000	mm	2.000	1.500	2.000	2.500	1.500	2.500	2.500	3.000	3.000	3.500
Thread (D)	mm	M33	M36	M39	M42	M45	M48	M52	M56	M60	M64
Diameter	Inch	1.299	1.417	1.535	1.654	1.722	1.890	2.047	2.205	2.362	2.520
Pitch	mm	3.500	4.000	4.000	4.500	4.500	5.000	5.000	5.500	5.500	6.000

### Note:

- Measurements are subject to 5% tolerance.
- Other Sizes available on request.
- Left Handed is Available upon request.
- Hot Dipped Galvanized can be supplied upon request.
- SHIELD reserves the right to change the contents without notice.

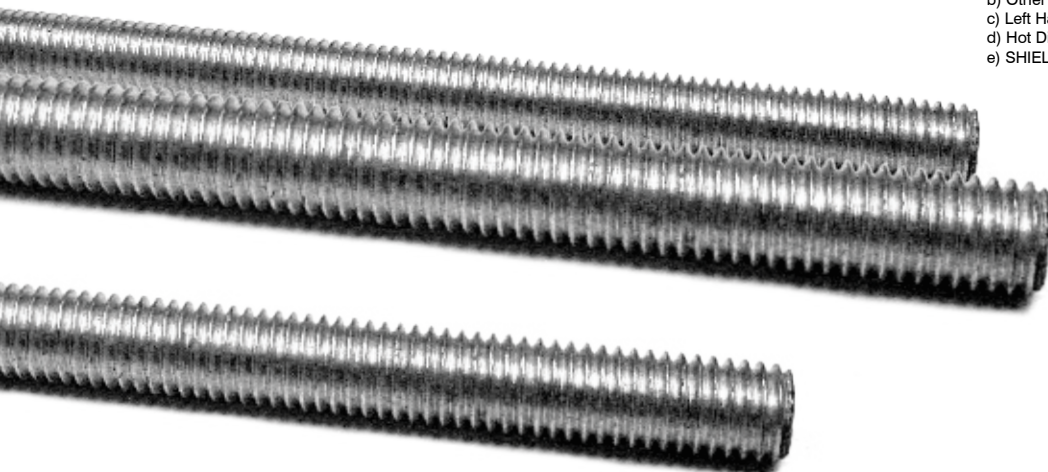

# Shield Beam Clamp

## Features

Beam Clamps are designed to clamp hanger rod to the beam's top flange or bar joist. Universal open U design allows for adjustments and permissible to use in an inverted position on the bottom flange of the beam also.

## Approval

Manufacturers Standardization Society ANSI/MSS SP-69 (Type 19 & 23)  
Federal Specification WW-H-171E (Type 23) & A-A-1192A (Type 19 & 23)  
UL Listed/FM Approved.

## Material

Ductile Iron & Malleable Iron.

## Finishing

Electro galvanized as per ASTM B 633 Standards.

## Models

SD-CBC/CBCA 110 -  $\frac{3}{8}$ " (10mm)  
SD-CBC/CBCA 115 -  $\frac{1}{2}$ " (12mm)  
SD-CBC 210 -  $\frac{3}{8}$ " (10mm)

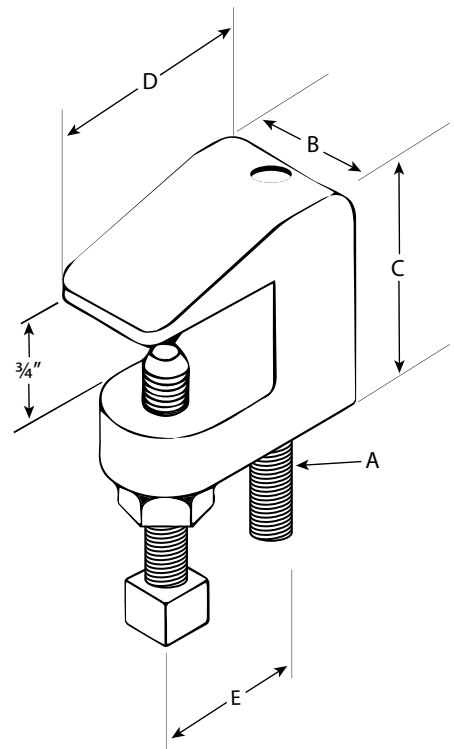

## SD-CBC

Models	Rod Size A Inch (mm)	Dimensions				Max. Pipe Size Inch	Max. Load Kg
		B mm	C mm	D mm	E mm		
SD-CBC/CBCA 110	$\frac{3}{8}$ (10)	21.00	40.00	49.0	42.00	4	250
SD-CBC/CBCA 115	$\frac{1}{2}$ (12)	25.00	42.50	52.0	49.00	8	750

### Note:

- a) Measurements are subject to 5% tolerance.
- b) Other Sizes available on request.
- c) Hot Dipped Galvanized can be supplied upon request.
- d) Refer to UL/FM certificates for more information.
- e) SHIELD reserves the right to change the contents without notice.



# Factory Mutual System









For further information on any aspect of the  
Shield range of Pipes & Fittings please contact your nearest office.

**United Kingdom**

Unit 3, Endeavour Drive,  
Basildon-Essex, SS14 3WF, U.K.  
Email: [info@shieldglobal.com](mailto:info@shieldglobal.com)  
Tel: + 44 (0) 1708 377731  
Fax: + 44 (0) 1708 347637

**Middle East & Africa**

Jebel Ali Free Zone, Dubai, U.A.E.  
Email: [shieldme@shieldglobal.com](mailto:shieldme@shieldglobal.com)  
Tel: + 971 4 881 2070  
Fax: + 971 4 881 2198



**SHIELD**

[www.shieldglobal.com](http://www.shieldglobal.com)